

SMEL series

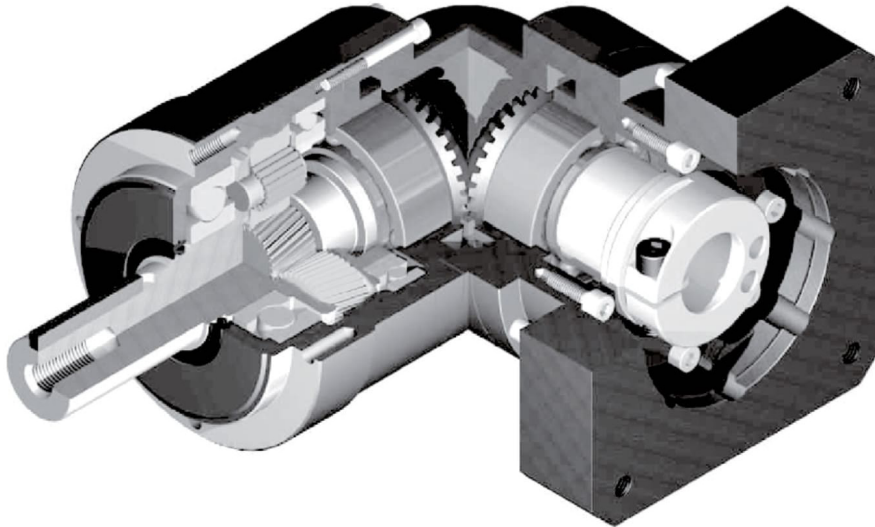

공간 절약

스파이럴 베벨기어를 적용한 직교형 감속기로, 출력축과 모터를 수직으로 위치시켜 공간절약 가능.

Space - saving

Right angle reducer using spiral bevel gear
Customer can locate the motor at 90 degree away from the reducer if required to save space.

고강성 & 고토크

Uncaged 니들롤러베어링을 사용하여 강성과 토크 향상.

High rigidity & torque

High rigidity & high torque was achieved by uncaged needle roller bearings.

어댑터-부싱 연결방식

다양한 모터에 취부 가능.

Adapter-bushing connection

Can be attached to any motor all over the world.

그리스 누유현상 없음

고점도 분리방지 그리스를 사용.

No grease leakage

Perfect solution by high viscosity anti-separation grease.

유지 보수 불필요

제품 수명 동안 그리스 교체 불필요 자유로운 설치 가능.

Maintenance-free

No need to replace the grease for the life time.
Can be attached in any position.

SMEL series

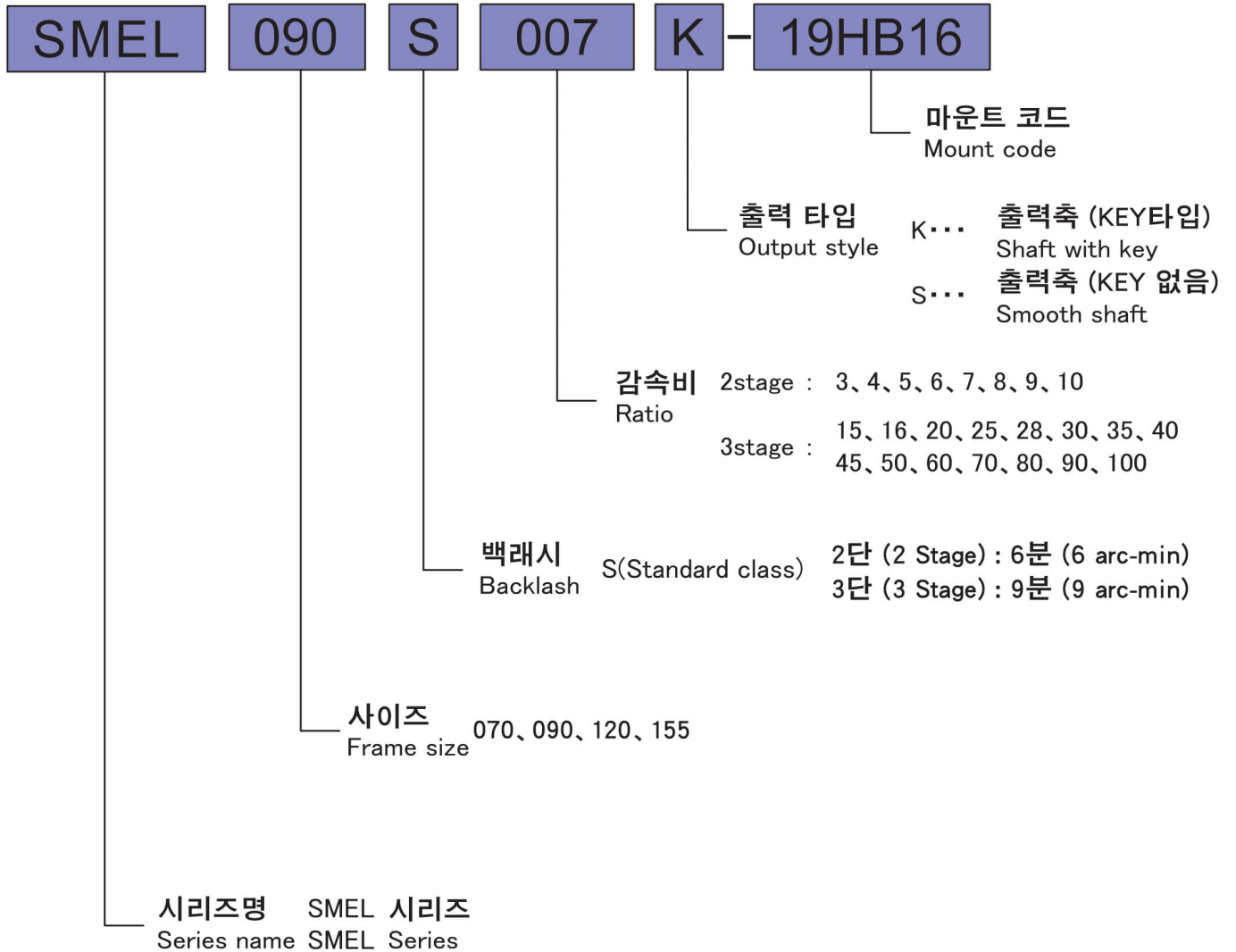

Model No.		Unit	Stage	Ratio ¹	SMEL070	SMEL090	SMEL120	SMEL155	
Rated Output Torque (Nominal Output torque)	T _{2N}	Nm	2	3	33	89	195	440	
				4	39	110	210	460	
				5	43	110	210	580	
				6	43	108	160	530	
				7	43	108	200	490	
				8	43	79	190	420	
				9	35	90	170	390	
				10	30	88	170	370	
				3	15	35	84	195	440
					16	39	100	210	460
			20		39	100	210	460	
			25		43	110	210	580	
			28		43	108	200	580	
			30		39	90	195	440	
			35		43	108	200	580	
			40		43	110	210	460	
			45		39	90	170	580	
			50		43	110	210	580	
			60	43	108	160	580		
			70	43	108	200	490		
80	43	79	190	420					
90	39	90	170	390					
100	39	88	170	370					
Max. Acceleration Torque	T _{2B}	Nm	2,3	3~100	1.8 Times of Rated Output Torque				
Max. Output Torque Emergency Stop Torque	T _{2NOT}	Nm	2,3	3~100	3 Times of Rated Output Torque				
Nominal Input speed	n _{1n}	rpm	2,3	3~100	3,000	3,000	3,000	2,000	
Max. Input speed	n _{1B}	rpm	2,3	3~100	6,000	6,000	6,000	5,000	
Backlash (Standard class)		arcmin	2	3~10	≤6	≤6	≤6	≤6	
			3	15~100	≤9	≤9	≤9	≤9	
Torsional Rigidity		Nm/arcmin	2,3	3~100	5	12	23	38	
Max. Radial load ²	F _{2rB}	N	2,3	3~100	1,100	2,150	3,600	7,500	
Max. Axial load ²	F _{2aB}	N	2,3	3~100	600	1,800	2,500	3,000	
Service life	L _H	hr	2,3	3~100	20,000	20,000	20,000	20,000	
Noise level ³		dB(A)	2,3	3~100	≤ 63	≤ 65	≤68	≤ 70	
Weight		kg	2	3~10	1.8	5.1	10.4	19.1	
			3	15~100	2.1	4.4	10.1	19.6	
Mass Moments of Inertia ⁴		kg cm ²	2	3~10	0.32	2.13	6.61	21.28	
			3	15~100	0.12	0.59	4.64	14.82	
Operating Temp. ⁵		°C	2,3	3~100	-10 ~ +90				
Lubrication			2,3	3~100	High temperature & Extreme pressure Lubricant				
Mounting position			2,3	3~100	All directions				
Efficiency	η	%	2	3~10	≥ 95				
			3	15~100	≥ 92				
Degree of protection			2,3	3~100	IP 65				

(1) Ratio (감속비) = Nin / Nout

(2) 기준 : 출력회전수 100rpm, 출력축 중앙 부하, 부하계수(Ka)=1, 연속운전 10,000시간

These values are based on the following conditions : 100 rpm at the output. Load applied to the middle of the output shaft. Load coefficient(Ka)=1. Continuous operation(S1≒10,000hrs).

(3) 입력 회전수 3000 rpm, 무부하 운전상태에서 감속기 취부면에서 1m 떨어진 거리에서 측정 (모델에 따라 차이가 있을수 있습니다)

Noise level : A measurement 1m away from the reducer (with ratio10 or ratio 100), 3000 input rpm and at no load condition.

(Background noise 40dB(A)) With lower ratio and/or higher rpm, the noise level could be 3 to 5 dB higher.

(4) 관성모멘트 : 감속비 중 대표값 (i=1/5)

Moment of inertia : A measurement at the input shaft and representatives from each ratio.(i=1/5)

(5) 감속기 작동온도 : -10~+90 °C, 감속기 주위온도 -10~40°C

Operating temperature : Surface temperature of gear case in -10 °C~40 °C of ambient temperature.

※ 제품 성능 향상을 위해 사양은 별도의 고지 없이 변경될 수 있습니다.

Specifications are subject to change without notice to improve product performances.

SMEL 090 2단 2stage

입력축 내경 Input shaft bore $\leq \phi 14$

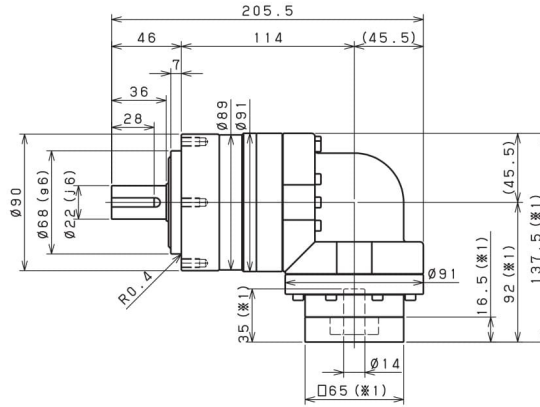
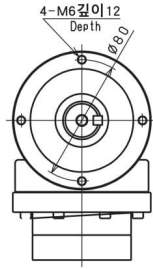

입력축 내경 Input shaft bore $\leq \phi 19$

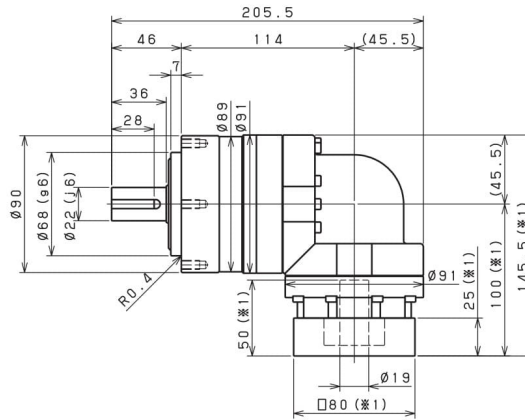
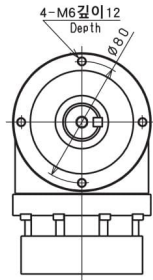

입력축 내경 Input shaft bore $\leq \phi 28$

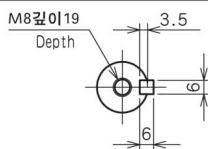
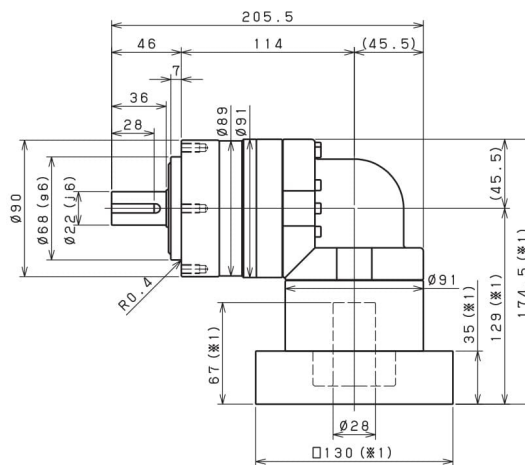
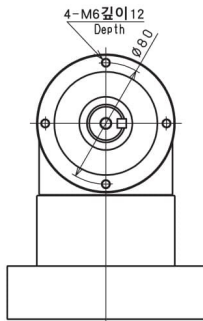

출력축 (KEY타입)
Shaft with key

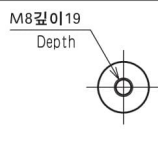

출력축 (KEY없음)
Smooth shaft

- ※1 적용 모터에 따라 길이는 변경될 수 있습니다.
- ※2 모터 축과 감속기의 입력축 내경이 다를 경우에는 부싱이 삽입됩니다.
- ※1 Length will vary depending on motor.
- ※2 Bushing will be inserted to adapt to motor shaft.

SMEL 090 3단 3stage

입력축 내경 Input shaft bore $\leq \phi 8$

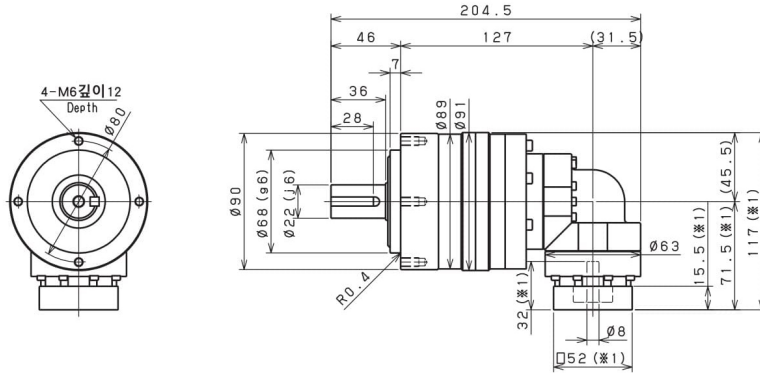

입력축 내경 Input shaft bore $\leq \phi 14$

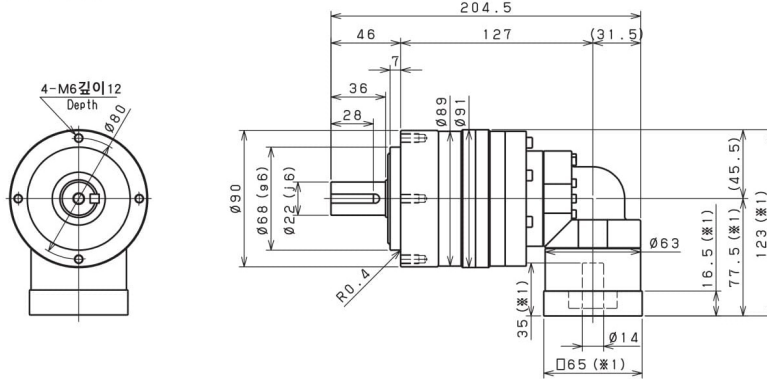

입력축 내경 Input shaft bore $\leq \phi 19$

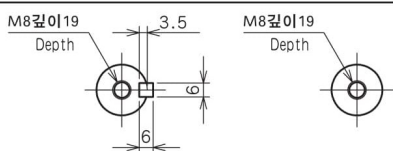
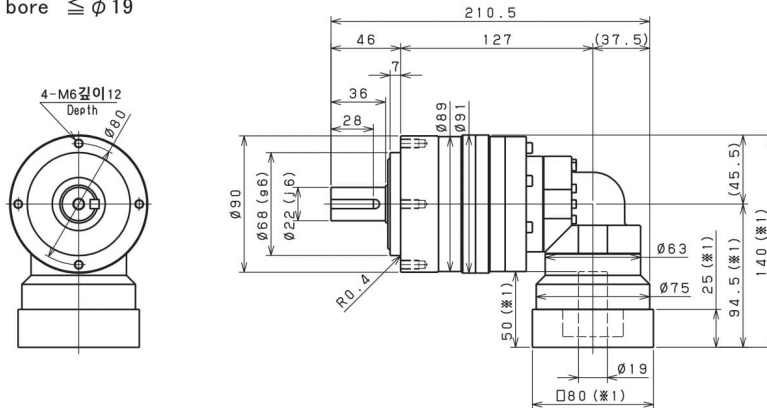

출력축 (KEY타입)
Shaft with key

출력축 (KEY없음)
Smooth shaft

- ※1 적용 모터에 따라 길이는 변경될 수 있습니다.
- ※2 모터 축과 감속기의 입력축 내경이 다를 경우에는 부싱이 삽입됩니다.
- ※1 Length will vary depending on motor.
- ※2 Bushing will be inserted to adapt to motor shaft.

SMEL 120 2단 2stage

입력축 내경 Input shaft bore $\leq \phi 19$

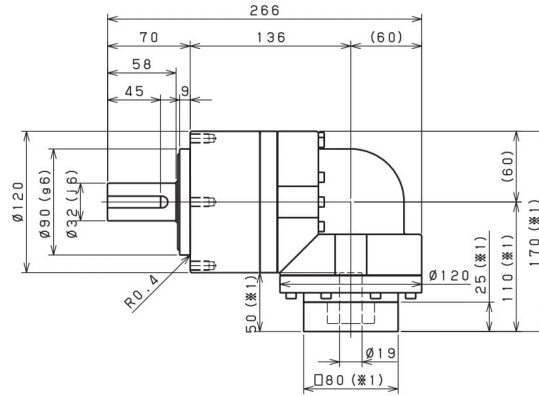
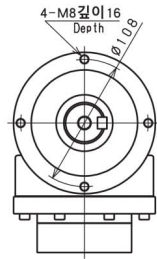

입력축 내경 Input shaft bore $\leq \phi 28$

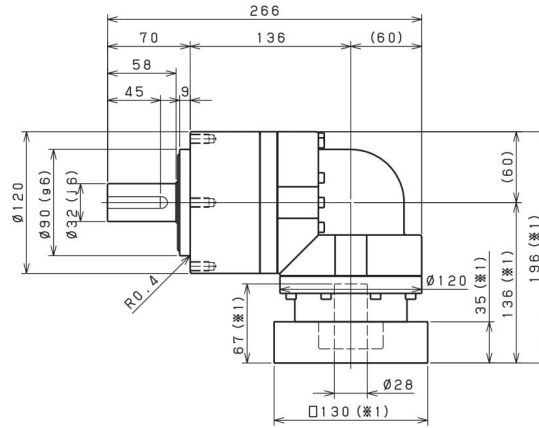
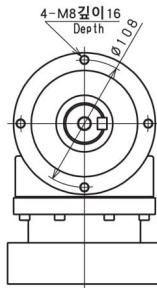

입력축 내경 Input shaft bore $\leq \phi 38$

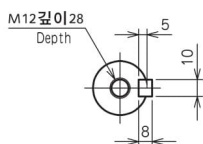
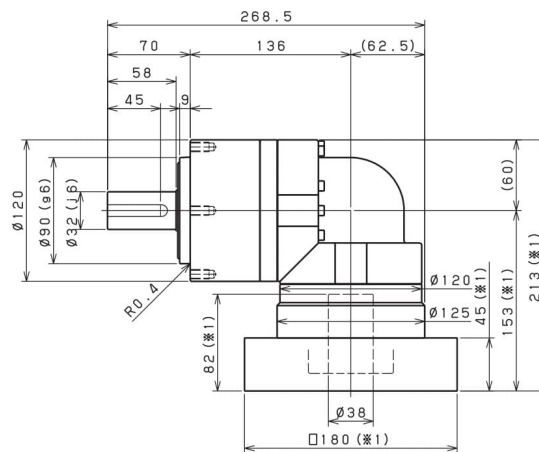
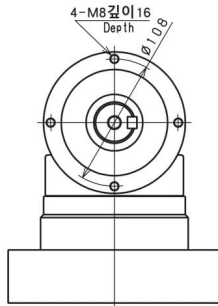

출력축 (KEY타입)
Shaft with key

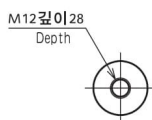

출력축 (KEY없음)
Smooth shaft

- ※1 적용 모터에 따라 길이는 변경될 수 있습니다.
- ※2 모터 축과 감속기의 입력축 내경이 다를 경우에는 부싱이 삽입됩니다.
- ※1 Length will vary depending on motor.
- ※2 Bushing will be inserted to adapt to motor shaft.

SMEL 120 3단 3stage

입력축 내경 Input shaft bore $\leq \phi 14$

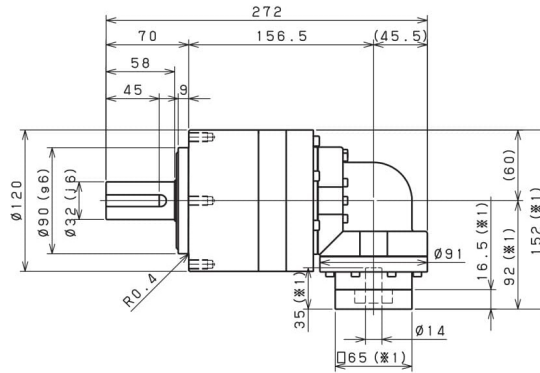
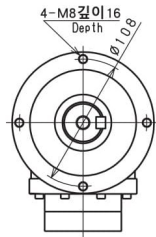

입력축 내경 Input shaft bore $\leq \phi 19$

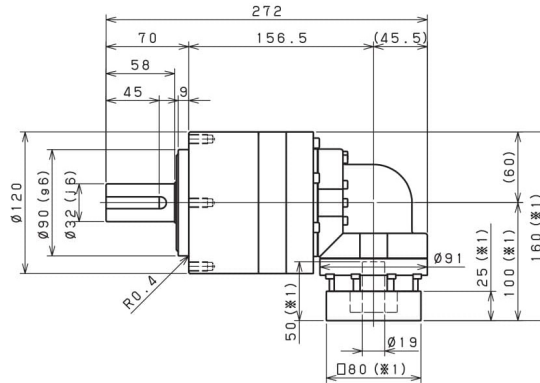
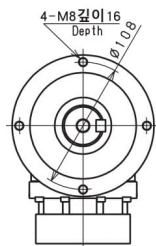

입력축 내경 Input shaft bore $\leq \phi 28$

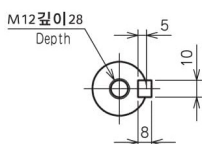
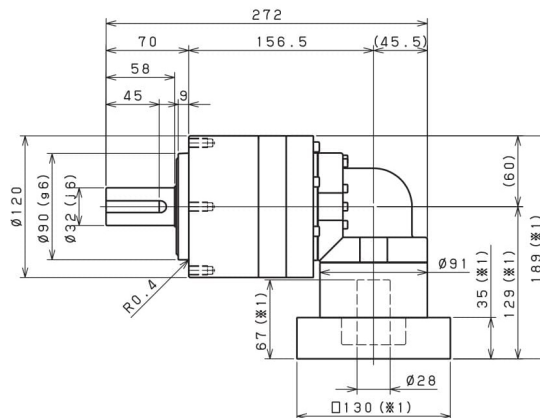
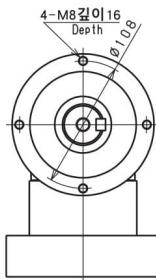

출력축 (KEY타입)
Shaft with key

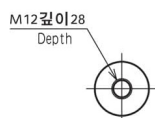

출력축 (KEY없음)
Smooth shaft

- ※1 적용 모터에 따라 길이는 변경될 수 있습니다.
- ※2 모터 축과 감속기의 입력축 내경이 다를 경우에는 부싱이 삽입됩니다.
- ※1 Length will vary depending on motor.
- ※2 Bushing will be inserted to adapt to motor shaft.

SMEL 155 2단 2stage

입력축 내경 Input shaft bore $\leq \phi 28$

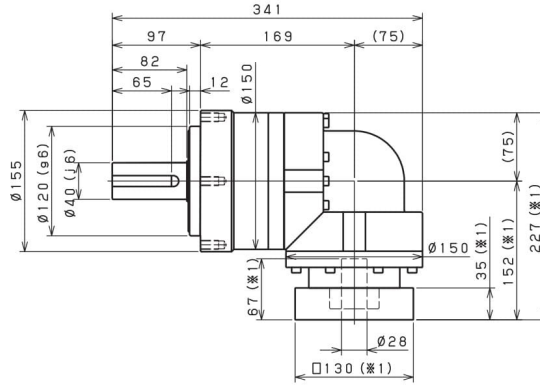
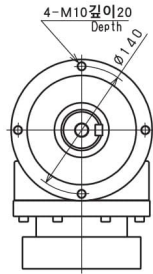

입력축 내경 Input shaft bore $\leq \phi 38$

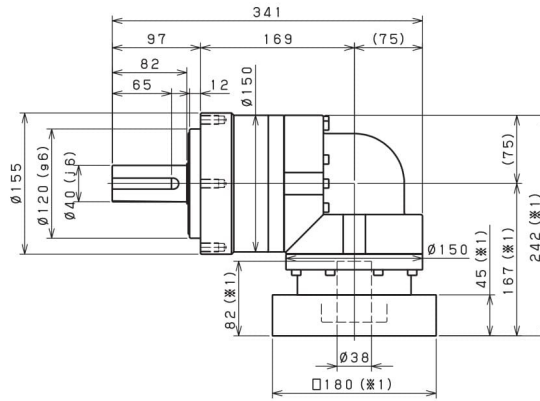
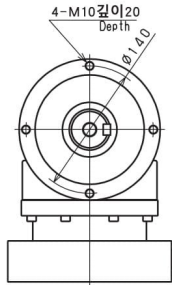

입력축 내경 Input shaft bore $\leq \phi 48$

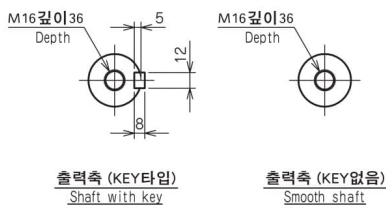
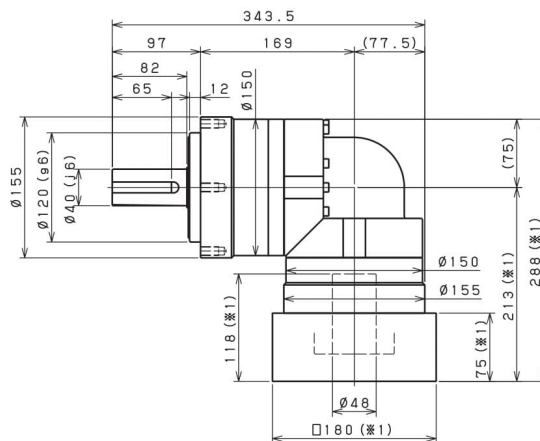
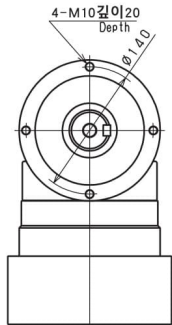

- ※ 1 적용 모터에 따라 길이는 변경될 수 있습니다.
- ※ 2 모터 축과 감속기의 입력축 내경이 다를 경우에는 부싱이 삽입됩니다.
- ※ 1 Length will vary depending on motor.
- ※ 2 Bushing will be inserted to adapt to motor shaft.

SMEL 155 3단 3stage

입력축 내경 Input shaft bore $\leq \phi 19$

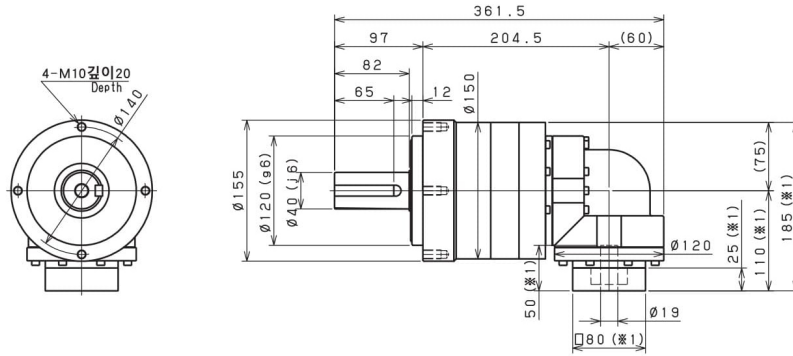

입력축 내경 Input shaft bore $\leq \phi 28$

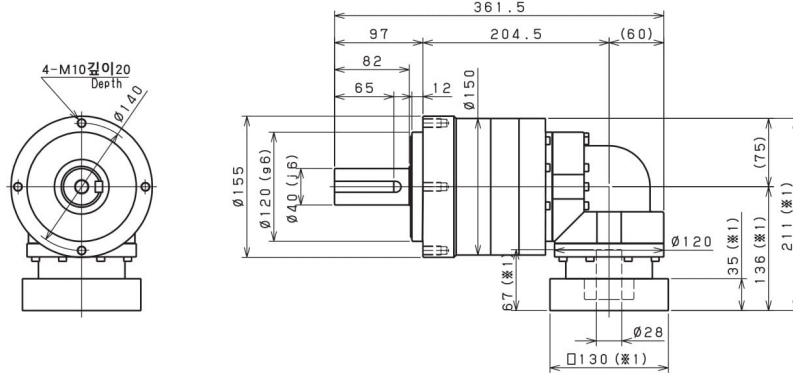

입력축 내경 Input shaft bore $\leq \phi 38$

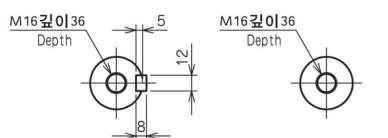
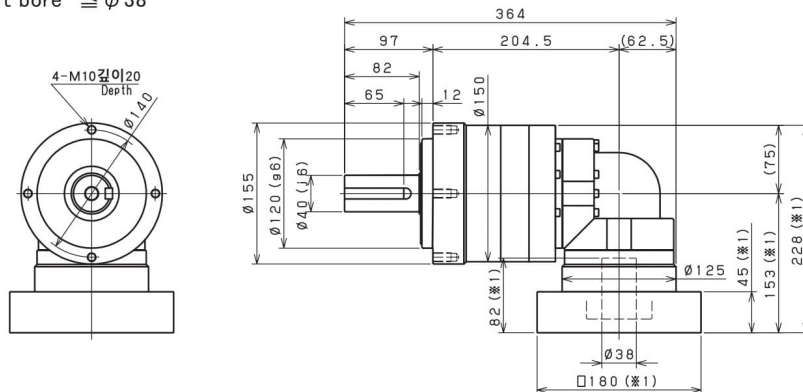

출력축 (KEY타입)
Shaft with key

출력축 (KEY없음)
Smooth shaft

- ※1 적용 모터에 따라 길이는 변경될 수 있습니다.
- ※2 모터 축과 감속기의 입력축 내경이 다를 경우에는 부싱이 삽입됩니다.
- ※1 Length will vary depending on motor.
- ※2 Bushing will be inserted to adapt to motor shaft.

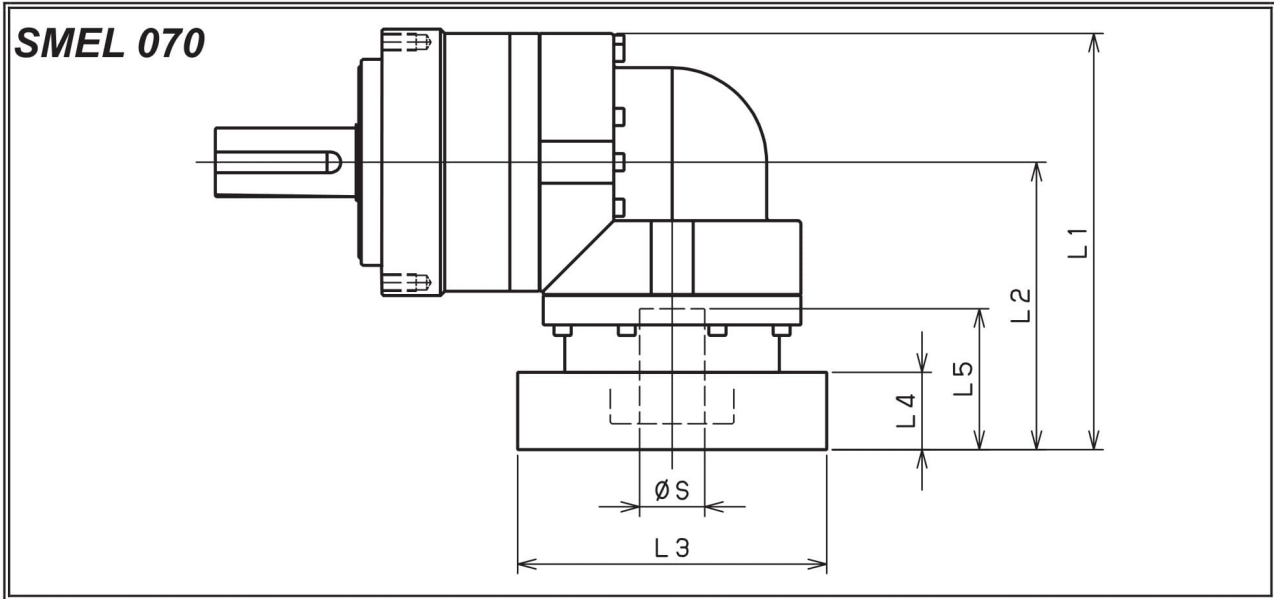

모델명 Model number	** : 어댑터 코드 ** : Adapter code (Mount code)	2단 Double					3단 Triple				
		L1	L2	L3	L4	L5	L1	L2	L3	L4	L5
SMEL070□□□-8** (S ≤ 8)	AA·AC·AD·AF·AG	106.5	71.5	□52	15.5	32	99.5	64.5	□52	15.5	32
	AB·AE·AH·AJ·AK	111.5	76.5	□52	20.5	37	104.5	69.5	□52	20.5	37
	BA·BB·BD·BE	106.5	71.5	□60	15.5	32	99.5	64.5	□60	15.5	32
	BC·BF	111.5	76.5	□60	20.5	37	104.5	69.5	□60	20.5	37
	CA	111.5	76.5	□70	20.5	37	104.5	69.5	□70	20.5	37
SMEL070□□□-14** (8 < S ≤ 14)	BA·BB·BD·BE·BF·BG·BJ·BK	112.5	77.5	□65	16.5	35	103.5	68.5	□65	16.5	35
	BC·BH	117.5	82.5	□65	21.5	40	108.5	73.5	□65	21.5	40
	BL	122.5	87.5	□65	26.5	45	113.5	78.5	□65	26.5	45
	CA	112.5	77.5	□70	16.5	35	103.5	68.5	□70	16.5	35
	CB	117.5	82.5	□70	21.5	40	108.5	73.5	□70	21.5	40
	DA·DB·DC·DD·DF·DH	112.5	77.5	□80	16.5	35	103.5	68.5	□80	16.5	35
	DE	117.5	82.5	□80	21.5	40	108.5	73.5	□80	21.5	40
	DG	122.5	87.5	□80	26.5	45	113.5	78.5	□80	26.5	45
	EA·EB·EC	112.5	77.5	□90	16.5	35	103.5	68.5	□90	16.5	35
	ED	122.5	87.5	□90	26.5	45	113.5	78.5	□90	26.5	45
	FA	112.5	77.5	□100	16.5	35	103.5	68.5	□100	16.5	35
	GA	112.5	77.5	□115	16.5	35	103.5	68.5	□115	16.5	35
SMEL070□□□-19** (14 < S ≤ 19)	DA·DB·DC	129.5	94.5	□80	25	50					
	DD	139.5	104.5	□80	35	60					
	DE	134.5	99.5	□80	30	55					
	EA	134.5	99.5	□90	30	55					
	EB	129.5	94.5	□90	25	50					
	EC	139.5	104.5	□90	35	60					
	FA	129.5	94.5	□100	25	50					
	FB	139.5	104.5	□100	35	60					
	GA·GC	134.5	99.5	□115	30	55					
	GB·GD	129.5	94.5	□115	25	50					
	HA	129.5	94.5	□130	25	50					
	HB	144.5	109.5	□130	40	65					
	HC·HD·HE	134.5	99.5	□130	30	55					

※ 1 2단 감속비: 1/3~1/10 ; 3단 감속비: 1/15~1/100

※ 1 Double reduction : 1/3 ~ 1/10, Triple reduction : 1/15 ~ 1/100

※ 2 모터 축과 감속기의 입력축 내경이 다를 경우에는 부싱이 삽입됩니다.

※ 2 Bushing will be inserted to adapt to motor shaft.

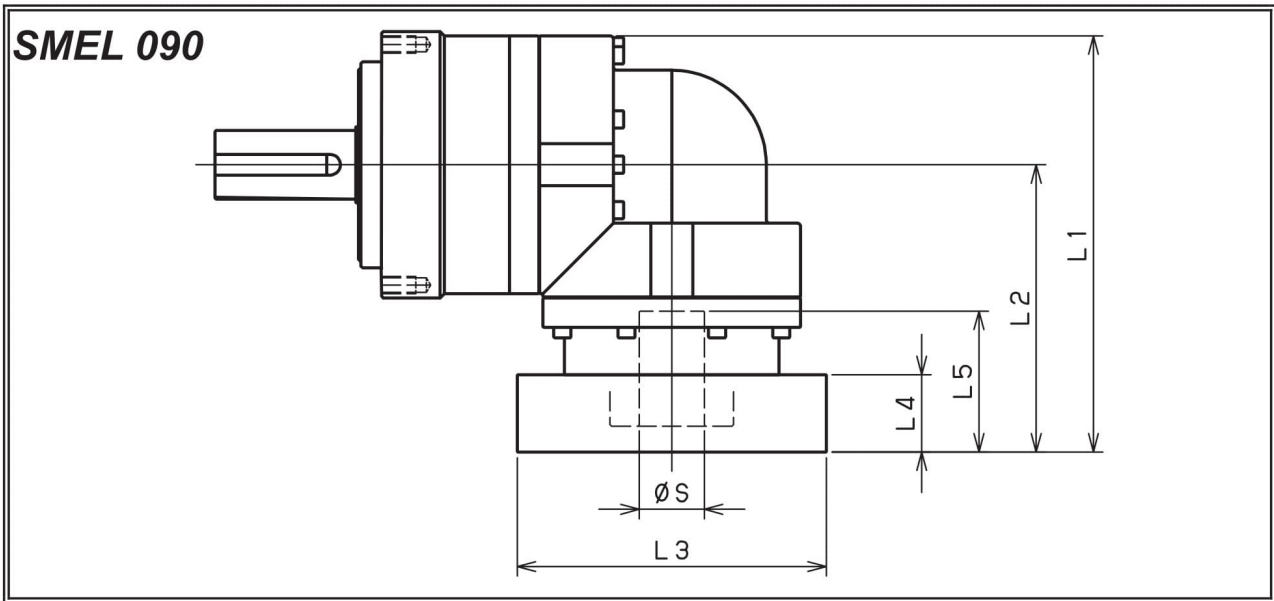

모델명 Model number	** : 어댑터 코드 ** : Adapter code (Mount code)	2단 Double					3단 Triple				
		L1	L2	L3	L4	L5	L1	L2	L3	L4	L5
SMEL090□□□-8** (S≤8)	AA·AC·AD·AF·AG	/	/	/	/	/	117	71.5	□52	15.5	32
	AB·AE·AH·AJ·AK	/	/	/	/	/	122	76.5	□52	20.5	37
	BA·BB·BD·BE	/	/	/	/	/	117	71.5	□60	15.5	32
	BC·BF	/	/	/	/	/	122	76.5	□60	20.5	37
	CA	/	/	/	/	/	122	76.5	□70	20.5	37
SMEL090□□□-14** (8<S≤14)	BA·BB·BD·BE·BF·BG·BJ·BK	137.5	92	□65	16.5	35	123	77.5	□65	16.5	35
	BC·BH	142.5	97	□65	21.5	40	128	82.5	□65	21.5	40
	BL	147.5	102	□65	26.5	45	133	87.5	□65	26.5	45
	CA	137.5	92	□70	16.5	35	123	77.5	□70	16.5	35
	CB	142.5	97	□70	21.5	40	128	82.5	□70	21.5	40
	DA·DB·DC·DD·DF·DH	137.5	92	□80	16.5	35	123	77.5	□80	16.5	35
	DE	142.5	97	□80	21.5	40	128	82.5	□80	21.5	40
	DG	147.5	102	□80	26.5	45	133	87.5	□80	26.5	45
	EA·EB·EC	137.5	92	□90	16.5	35	123	77.5	□90	16.5	35
	ED	147.5	102	□90	26.5	45	133	87.5	□90	26.5	45
	FA	137.5	92	□100	16.5	35	123	77.5	□100	16.5	35
	GA	137.5	92	□115	16.5	35	123	77.5	□115	16.5	35
SMEL090□□□-19** (14<S≤19)	DA·DB·DC	145.5	100	□80	25	50	140	94.5	□80	25	50
	DD	155.5	110	□80	35	60	150	104.5	□80	35	60
	DE	150.5	105	□80	30	55	145	99.5	□80	30	55
	EA	150.5	105	□90	30	55	145	99.5	□90	30	55
	EB	145.5	100	□90	25	50	140	94.5	□90	25	50
	EC	155.5	110	□90	35	60	150	104.5	□90	35	60
	FA	145.5	100	□100	25	50	140	94.5	□100	25	50
	FB	155.5	110	□100	35	60	150	104.5	□100	35	60
	GA·GC	150.5	105	□115	30	55	145	99.5	□115	30	55
	GB·GD	145.5	100	□115	25	50	140	94.5	□115	25	50
	HA	145.5	100	□130	25	50	140	94.5	□130	25	50
	HB	160.5	115	□130	40	65	155	109.5	□130	40	65
HC·HD·HE	150.5	105	□130	30	55	145	99.5	□130	30	55	
SMEL090□□□-28** (19<S≤28)	FA·FB·FC	174.5	129	□100	35	67	/	/	/	/	/
	GA·GB·GC·GD·GE·GF·GG	174.5	129	□115	35	67	/	/	/	/	/
	HA·HC·HD	174.5	129	□130	35	67	/	/	/	/	/
	HB	184.5	139	□130	45	77	/	/	/	/	/
	JA·JB·JC	174.5	129	□150	35	67	/	/	/	/	/
	KA·KB	174.5	129	□180	35	67	/	/	/	/	/
	LA	174.5	129	□200	35	67	/	/	/	/	/
MA	174.5	129	□220	35	67	/	/	/	/	/	

※ 1 2단 감속비: 1/3~1/10 ; 3단 감속비: 1/15~1/100

※ 2 모터 축과 감속기의 입력축 내경이 다를 경우에는 부싱이 삽입됩니다.

※ 1 Double reduction : 1/3 ~ 1/10, Triple reduction : 1/15 ~ 1/100

※ 2 Bushing will be inserted to adapt to motor shaft.

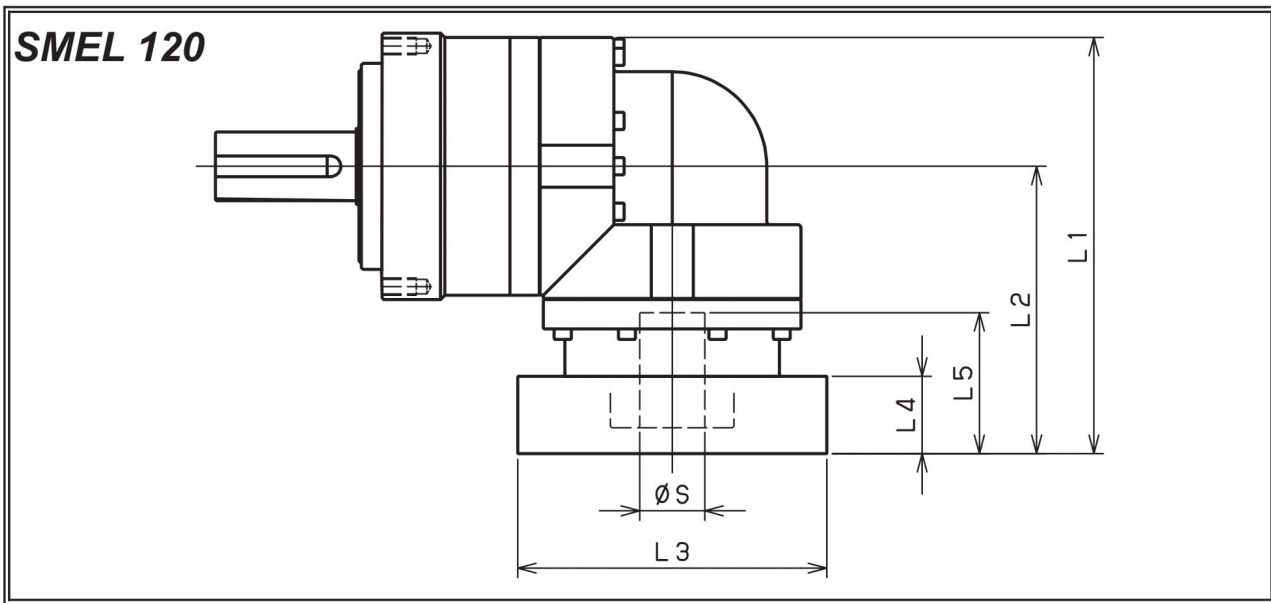

모델명 Model number	** : 어댑터 코드 ** : Adapter code (Mount code)	2단 Double					3단 Triple				
		L1	L2	L3	L4	L5	L1	L2	L3	L4	L5
SMEL120□□□-14** (S ≤ 14)	BA·BB·BD·BE·BF·BG·BJ·BK	/	/	/	/	/	152	92	□65	16.5	35
	BC·BH	/	/	/	/	/	157	97	□65	21.5	40
	BL	/	/	/	/	/	162	102	□65	26.5	45
	CA	/	/	/	/	/	152	92	□70	16.5	35
	CB	/	/	/	/	/	157	97	□70	21.5	40
	DA·DB·DC·DD·DF·DH	/	/	/	/	/	152	92	□80	16.5	35
	DE	/	/	/	/	/	157	97	□80	21.5	40
	DG	/	/	/	/	/	162	102	□80	26.5	45
	EA·EB·EC	/	/	/	/	/	152	92	□90	16.5	35
	ED	/	/	/	/	/	162	102	□90	26.5	45
	FA	/	/	/	/	/	152	92	□100	16.5	35
	GA	/	/	/	/	/	152	92	□115	16.5	35
SMEL120□□□-19** (14 < S ≤ 19)	DA·DB·DC	170	110	□80	25	50	160	100	□80	25	50
	DD	180	120	□80	35	60	170	110	□80	35	60
	DE	175	115	□80	30	55	165	105	□80	30	55
	EA	175	115	□90	30	55	165	105	□90	30	55
	EB	170	110	□90	25	50	160	100	□90	25	50
	EC	180	120	□90	35	60	170	110	□90	35	60
	FA	170	110	□100	25	50	160	100	□100	25	50
	FB	180	120	□100	35	60	170	110	□100	35	60
	GA·GC	175	115	□115	30	55	165	105	□115	30	55
	GB·GD	170	110	□115	25	50	160	100	□115	25	50
	HA	170	110	□130	25	50	160	100	□130	25	50
	HB	185	125	□130	40	65	175	115	□130	40	65
HC·HD·HE	175	115	□130	30	55	165	105	□130	30	55	
SMEL120□□□-28** (19 < S ≤ 28)	FA·FB·FC	196	136	□100	35	67	189	129	□100	35	67
	GA·GB·GC·GD·GE·GF·GG	196	136	□115	35	67	189	129	□115	35	67
	HA·HC·HD	196	136	□130	35	67	189	129	□130	35	67
	HB	206	146	□130	45	77	199	139	□130	45	77
	JA·JB·JC	196	136	□150	35	67	189	129	□150	35	67
	KA·KB	196	136	□180	35	67	189	129	□180	35	67
	LA	196	136	□200	35	67	189	129	□200	35	67
	MA	196	136	□220	35	67	189	129	□220	35	67
SMEL120□□□-38** (28 < S ≤ 38)	HA	213	153	□130	45	82	/	/	/	/	/
	HB	208	148	□130	40	77	/	/	/	/	/
	JA	213	153	□150	45	82	/	/	/	/	/
	KA·KB·KC	213	153	□180	45	82	/	/	/	/	/
	LA	213	153	□200	45	82	/	/	/	/	/
	LB	223	163	□200	55	92	/	/	/	/	/
	MA·MB	213	153	□220	45	82	/	/	/	/	/
	NA	213	153	□250	45	82	/	/	/	/	/

※ 1 2단 감속비: 1/3~1/10 ; 3단 감속비: 1/15~1/100

※ 2 모터 축과 감속기의 입력축 내경이 다를 경우에는 부싱이 삽입됩니다.

※ 1 Double reduction : 1/3 ~ 1/10, Triple reduction : 1/15 ~ 1/100

※ 2 Bushing will be inserted to adapt to motor shaft.

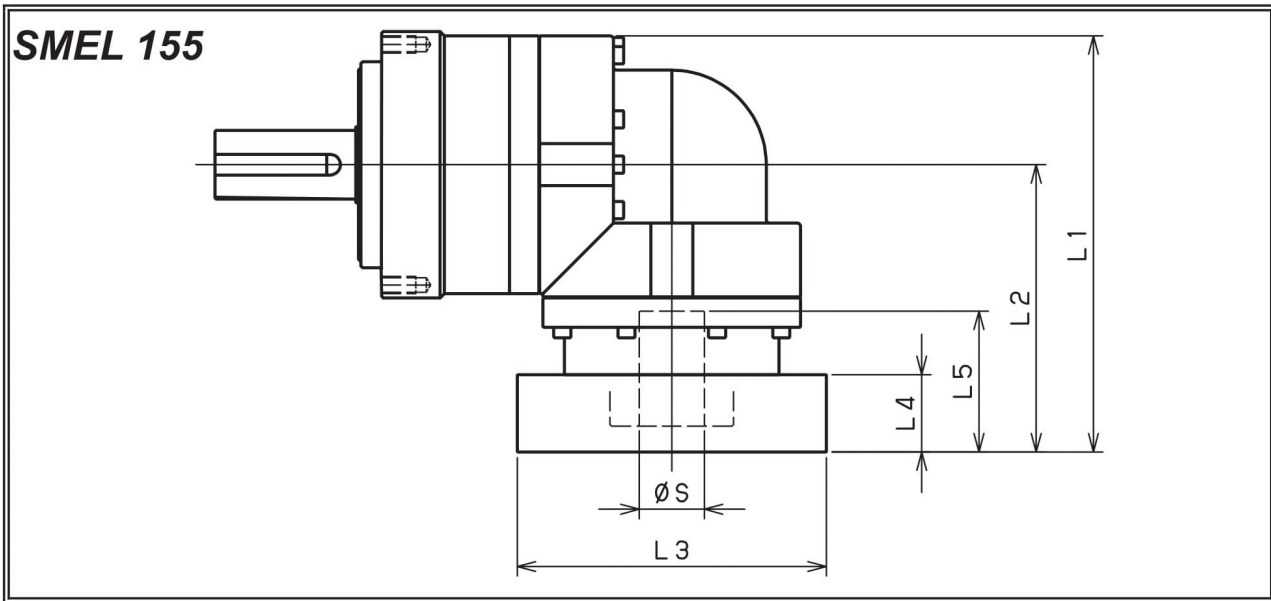

모델명 Model number	** : 어댑터 코드 ** : Adapter code (Mount code)	2단 Double					3단 Triple				
		L1	L2	L3	L4	L5	L1	L2	L3	L4	L5
SMEL155□□□-19** (S ≤ 19)	DA·DB·DC	/	/	/	/	/	187.5	110	□80	25	50
	DD	/	/	/	/	/	197.5	120	□80	35	60
	DE	/	/	/	/	/	192.5	115	□80	30	55
	EA	/	/	/	/	/	192.5	115	□90	30	55
	EB	/	/	/	/	/	187.5	110	□90	25	50
	EC	/	/	/	/	/	197.5	120	□90	35	60
	FA	/	/	/	/	/	187.5	110	□100	25	50
	FB	/	/	/	/	/	197.5	120	□100	35	60
	GA·GC	/	/	/	/	/	192.5	115	□115	30	55
	GB·GD	/	/	/	/	/	187.5	110	□115	25	50
	HA	/	/	/	/	/	187.5	110	□130	25	50
	HB	/	/	/	/	/	202.5	125	□130	40	65
	HC·HD·HE	/	/	/	/	/	192.5	115	□130	30	55
SMEL155□□□-28** (19 < S ≤ 28)	FA·FB·FC	229.5	152	□100	35	67	213.5	136	□100	35	67
	GA·GB·GC·GD·GE·GF·GG	229.5	152	□115	35	67	213.5	136	□115	35	67
	HA·HC·HD	229.5	152	□130	35	67	213.5	136	□130	35	67
	HB	239.5	162	□130	45	77	223.5	146	□130	45	77
	JA·JB·JC	229.5	152	□150	35	67	213.5	136	□150	35	67
	KA·KB	229.5	152	□180	35	67	213.5	136	□180	35	67
	LA	229.5	152	□200	35	67	213.5	136	□200	35	67
MA	229.5	152	□220	35	67	213.5	136	□220	35	67	
SMEL155□□□-38** (28 < S ≤ 38)	HA	244.5	167	□130	45	82	230.5	153	□130	45	82
	HB	239.5	162	□130	40	77	225.5	148	□130	40	77
	JA	244.5	167	□150	45	82	230.5	153	□150	45	82
	KA·KB·KC	244.5	167	□180	45	82	230.5	153	□180	45	82
	LA	244.5	167	□200	45	82	230.5	153	□200	45	82
	LB	254.5	177	□200	55	92	240.5	163	□200	55	92
	MA·MB	244.5	167	□220	45	82	230.5	153	□220	45	82
NA	244.5	167	□250	45	82	230.5	153	□250	45	82	
SMEL155□□□-48** (38 < S ≤ 48)	KB·KC	270.5	193	□180	55	98	/	/	/	/	/
	KA	290.5	213	□180	75	118	/	/	/	/	/
	LA	270.5	193	□200	55	98	/	/	/	/	/
	MA	270.5	193	□220	55	98	/	/	/	/	/
	MB	290.5	213	□220	75	118	/	/	/	/	/
	NA	290.5	213	□250	75	118	/	/	/	/	/
PA	290.5	213	□280	75	118	/	/	/	/	/	

※ 1 2단 감속비: 1/3~1/10 ; 3단 감속비: 1/15~1/100

※ 2 모터 축과 감속기의 입력축 내경이 다를 경우에는 부싱이 삽입됩니다.

※ 1 Double reduction : 1/3 ~ 1/10, Triple reduction : 1/15 ~ 1/100

※ 2 Bushing will be inserted to adapt to motor shaft.