

SMES series

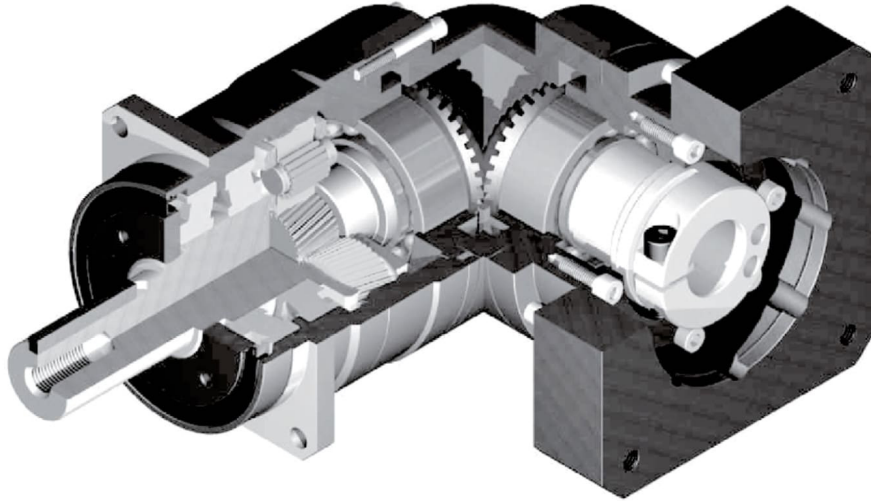

공간 절약

스파이럴 베벨기어를 적용한 직교형 감속기로, 출력축과 모터를 수직으로 위치시켜 공간절약 가능.

Space - saving

Right angle reducer using spiral bevel gear
Customer can locate the motor at 90 degree away from the reducer if required to save space.

고강성 & 고토크

Uncaged 니들롤러베어링을 사용하여 강성과 토크 향상.

High rigidity & torque

High rigidity & high torque was achieved by uncaged needle roller bearings.

고하중

출력축에 테이퍼롤러 베어링을 적용하여 레이디얼 및 액시얼 하중 증가.

High load capacity

Adopting taper roller bearing for the main output shaft to increase radial and axial load.

어댑터-부싱 연결방식

다양한 모터에 취부 가능.

Adapter-bushing connection

Can be attached to any motor all over the world.

그리스 누유현상 없음

고점도 분리방지 그리스를 사용.

No grease leakage

Perfect solution by high viscosity anti-separation grease.

유지 보수 불필요

제품 수명 동안 그리스 교체 불필요 자유로운 설치 가능.

Maintenance-free

No need to replace the grease for the life time.
Can be attached in any position.

SMES series

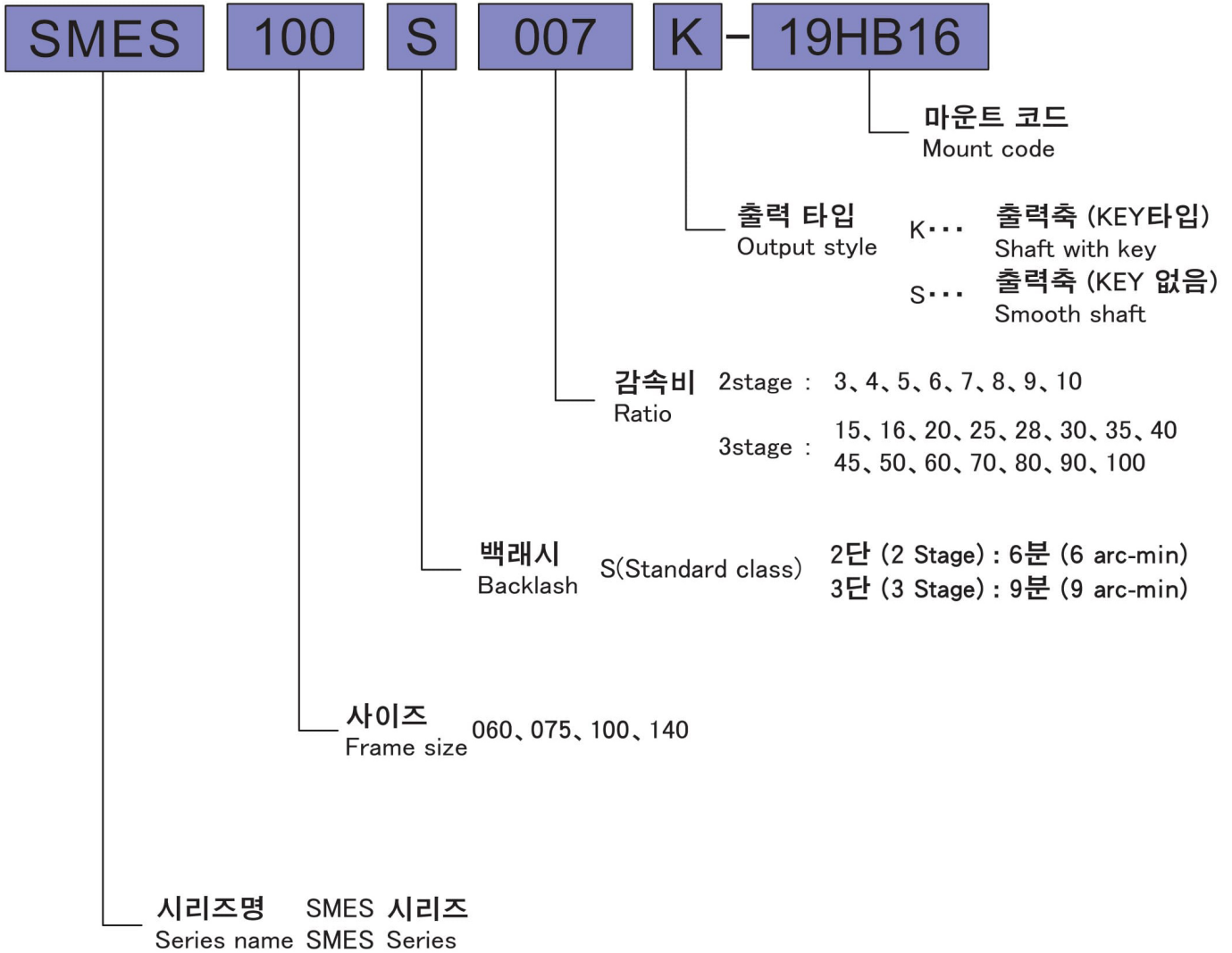

Model No.		Unit	Stage	Ratio ¹	SMES060	SMES075	SMES100	SMES140
Rated Output Torque (Nominal Output torque)	T_{2N}	Nm	2	3	33	89	195	440
				4	39	110	210	460
				5	43	110	210	580
				6	43	108	160	530
				7	43	108	200	490
				8	43	79	190	420
				9	35	90	170	390
				10	30	88	170	370
				15	35	84	195	440
				16	39	100	210	460
			3	20	39	100	210	460
				25	43	110	210	580
				28	43	108	200	580
				30	39	90	195	440
				35	43	108	200	580
				40	43	110	210	460
				45	39	90	170	580
				50	43	110	210	580
				60	43	108	160	580
				70	43	108	200	490
80	43	79	190	420				
90	39	90	170	390				
100	39	88	170	370				
Max. Acceleration Torque	T_{2B}	Nm	2,3	3~100	1.8 Times of Rated Output Torque			
Max. Output Torque Emergency Stop Torque	T_{2NOT}	Nm	2,3	3~100	3 Times of Rated Output Torque			
Nominal Input speed	n_{1n}	rpm	2,3	3~100	3,000	3,000	3,000	2,000
Max. Input speed	n_{1B}	rpm	2,3	3~100	6,000	6,000	6,000	5,000
Backlash (Standard class)		arcmin	2	3~10	≤6	≤6	≤6	≤6
			3	15~100	≤9	≤9	≤9	≤9
Torsional Rigidity		Nm/arcmin	2,3	3~100	5	12	23	38
Max. Radial load ²	F_{2rB}	N	2,3	3~100	3,000	4,300	6,900	10,000
Max. Axial load ²	F_{2aB}	N	2,3	3~100	2,700	3,900	6,300	90,000
Service life	L_H	hr	2,3	3~100	20,000	20,000	20,000	20,000
Noise level ³		dB(A)	2,3	3~100	≤63	≤65	≤68	≤70
Weight		kg	2	3~10	2	5.3	10.5	20.6
			3	15~100	2.1	4.4	10.1	20.7
Mass Moments of Inertia ⁴		kg cm ²	2	3~10	0.33	2.11	6.57	20.34
			3	15~100	0.12	0.59	4.63	14.82
Operating Temp. ⁵		°C	2,3	3~100	-10 ~ +90			
Lubrication			2,3	3~100	High temperature & Extreme pressure Lubricant			
Mounting position			2,3	3~100	All directions			
Efficiency	η	%	2	3~10	≥93			
			3	15~100	≥90			
Degree of protection			2,3	3~100	IP 65			

(1) Ratio (감속비) = N_{in} / N_{out}

(2) 기준 : 출력회전수 100rpm, 출력축 중앙 부하, 부하계수(Ka)=1, 연속운전 10,000시간

These values are based on the following conditions : 100 rpm at the output. Load applied to the middle of the output shaft.

Load coefficient(Ka)=1. Continuous operation(S1=10,000hrs).

(3) 입력 회전수 3000 rpm, 무부하 운전상태에서 감속기 취부면에서 1m 떨어진 거리에서 측정 (모델에 따라 차이가 있을수 있습니다)

Noise level : A measurement 1m away from the reducer (with ratio 10 or ratio 100), 3000 input rpm and at no load condition.

(Background noise 40dB(A)) With lower ratio and/or higher rpm, the noise level could be 3 to 5 dB higher.

(4) 관성모멘트 : 감속비 중 대표값 (i=1/5)

Moment of inertia : A measurement at the input shaft and representatives from each ratio.(i=1/5)

(5) 감속기 작동온도 : -10~+90 °C, 감속기 주위온도 -10~40°C

Operating temperature : Surface temperature of gear case in -10 °C~40 °C of ambient temperature.

※ 제품 성능 향상을 위해 사양은 별도의 고지 없이 변경될 수 있습니다.

Specifications are subject to change without notice to improve product performances.

SMES 060 3단 3stage

입력축 내경 Input shaft bore $\leq \phi 8$

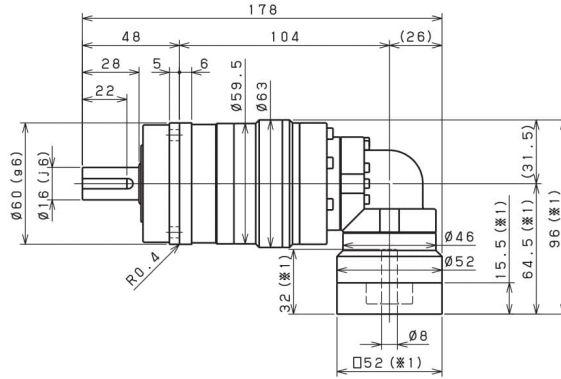
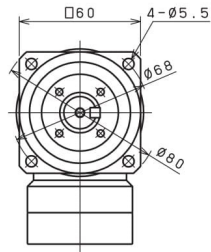

입력축 내경 Input shaft bore $\leq \phi 14$

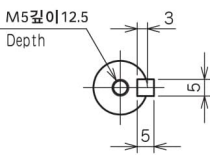
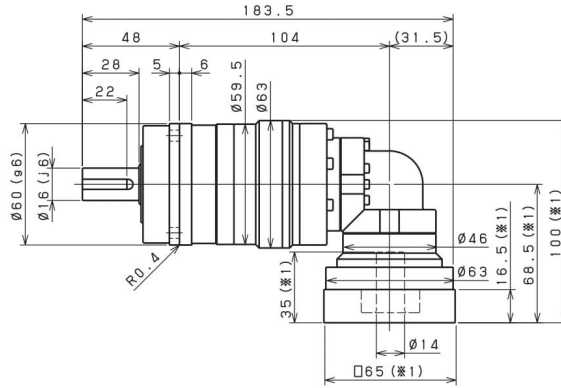
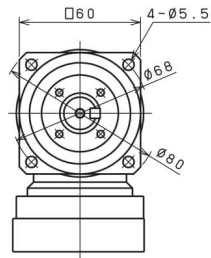

출력축 (KEY타입)
Shaft with key

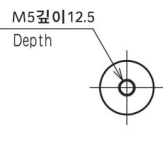

출력축 (KEY없음)
Smooth shaft

- ※1 적용 모터에 따라 길이는 변경될 수 있습니다.
- ※2 모터 축과 감속기의 입력축 내경이 다를 경우에는 부싱이 삽입됩니다.
- ※1 Length will vary depending on motor.
- ※2 Bushing will be inserted to adapt to motor shaft.

SMES 075 2단 2stage

입력축 내경 Input shaft bore $\leq \phi 14$

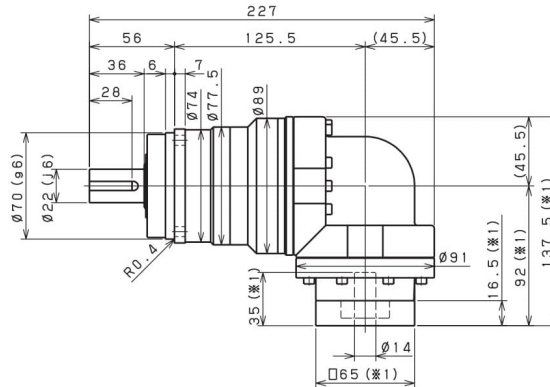
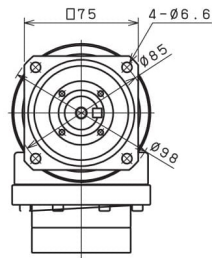

입력축 내경 Input shaft bore $\leq \phi 19$

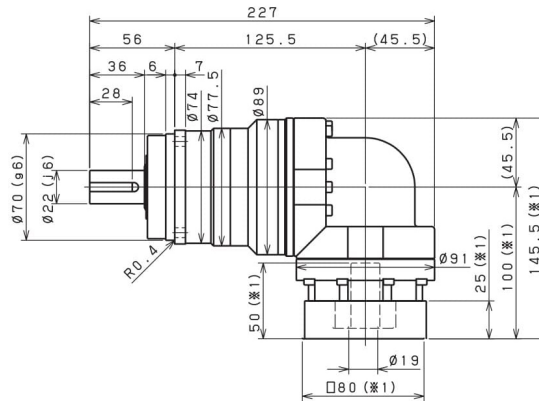
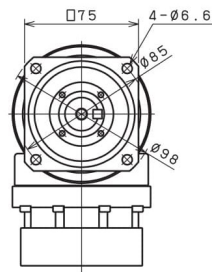

입력축 내경 Input shaft bore $\leq \phi 28$

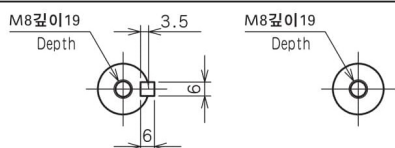
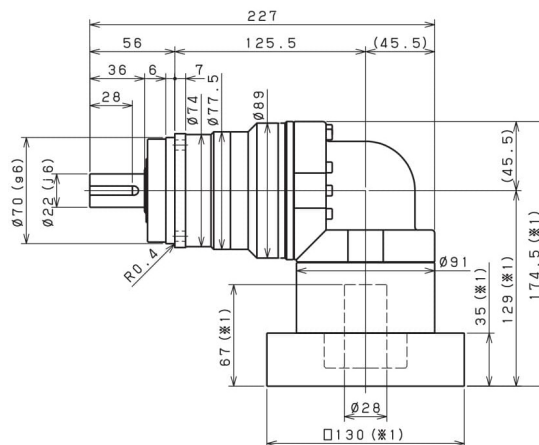
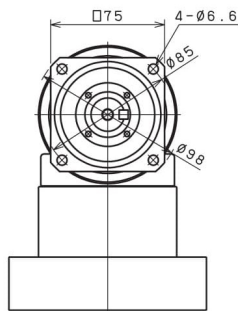

출력축 (KEY타입)
Shaft with key

출력축 (KEY없음)
Smooth shaft

- ※1 적용 모터에 따라 길이는 변경될 수 있습니다.
- ※2 모터 축과 감속기의 입력축 내경이 다를 경우에는 부싱이 삽입됩니다.
- ※1 Length will vary depending on motor.
- ※2 Bushing will be inserted to adapt to motor shaft.

SMES 075 3단 3stage

입력축 내경 Input shaft bore $\leq \phi 8$

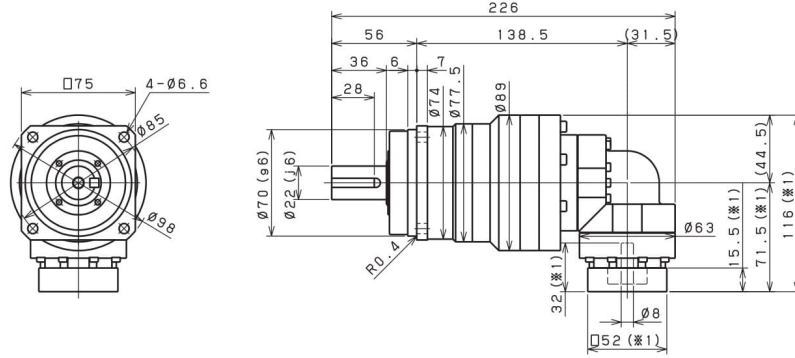

입력축 내경 Input shaft bore $\leq \phi 14$

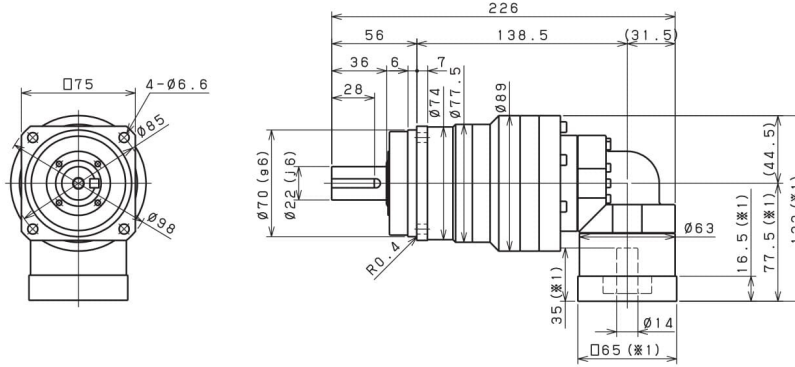

입력축 내경 Input shaft bore $\leq \phi 19$

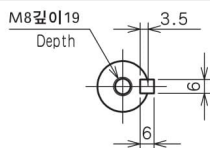
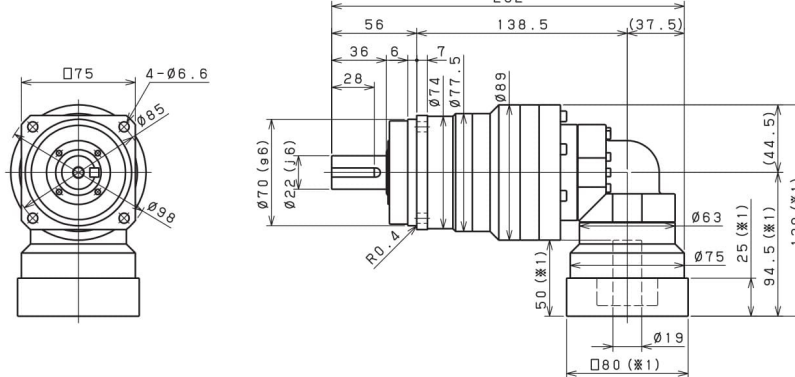

출력축 (KEY타입)
Shaft with key

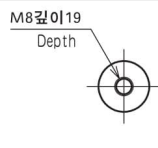

출력축 (KEY없음)
Smooth shaft

- ※1 적용 모터에 따라 길이는 변경될 수 있습니다.
- ※2 모터 축과 감속기의 입력축 내경이 다를 경우에는 부싱이 삽입됩니다.
- ※1 Length will vary depending on motor.
- ※2 Bushing will be inserted to adapt to motor shaft.

SMES 100 2단 2stage

입력축 내경 Input shaft bore $\leq \phi 19$

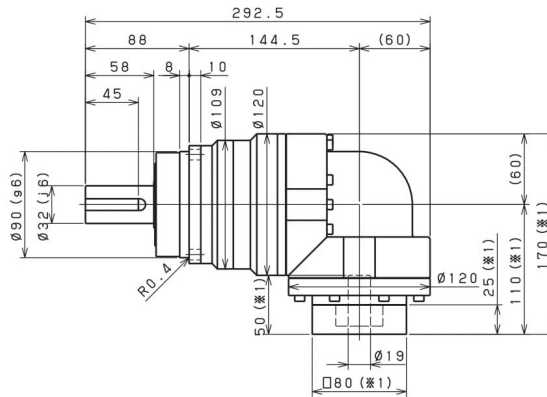
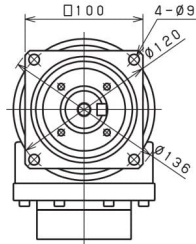

입력축 내경 Input shaft bore $\leq \phi 28$

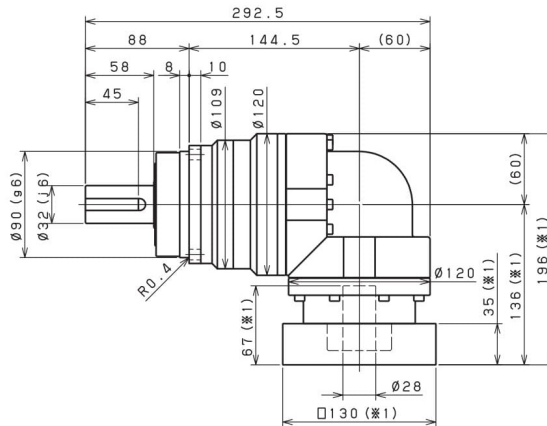
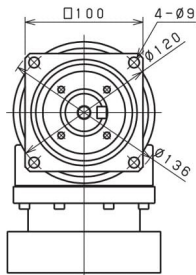

입력축 내경 Input shaft bore $\leq \phi 38$

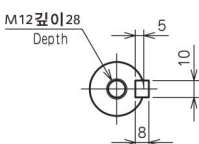
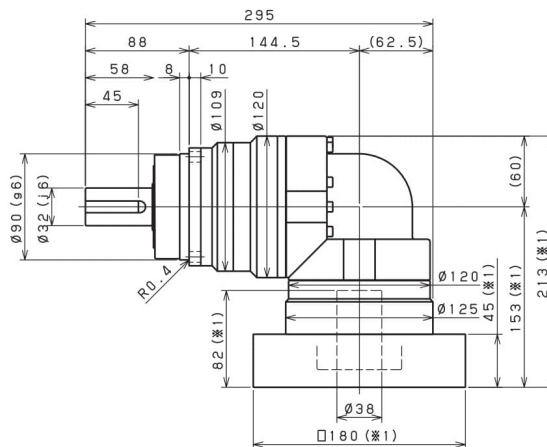
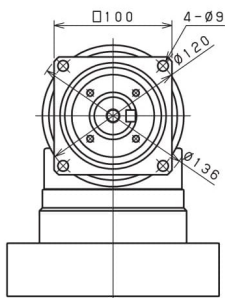

출력축 (KEY타입)
Shaft with key

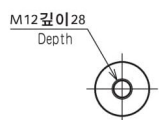

출력축 (KEY없음)
Smooth shaft

- ※1 적용 모터에 따라 길이는 변경될 수 있습니다.
- ※2 모터 축과 감속기의 입력축 내경이 다를 경우에는 부싱이 삽입됩니다.
- ※1 Length will vary depending on motor.
- ※2 Bushing will be inserted to adapt to motor shaft.

SMES 100 3단 3stage

입력축 내경 Input shaft bore $\leq \phi 14$

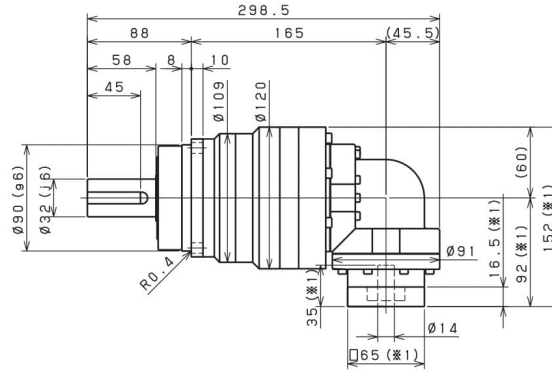
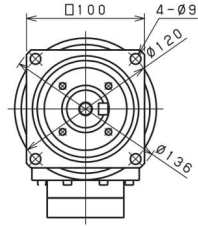

입력축 내경 Input shaft bore $\leq \phi 19$

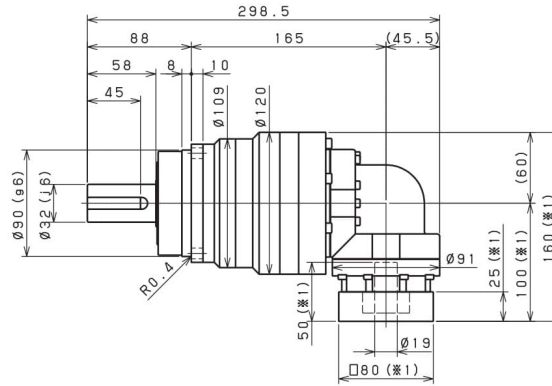
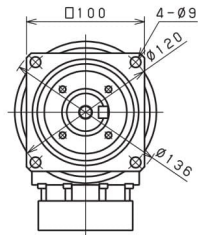

입력축 내경 Input shaft bore $\leq \phi 28$

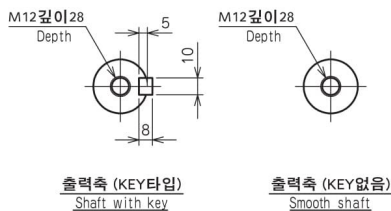
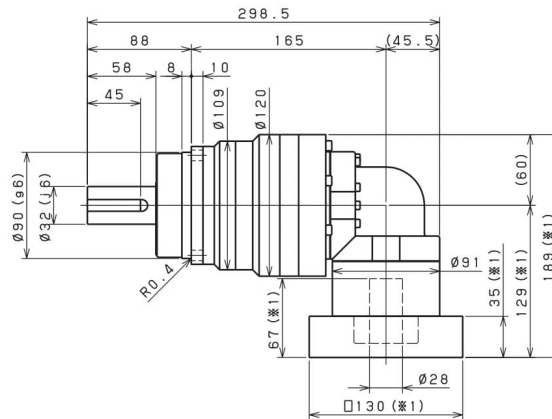
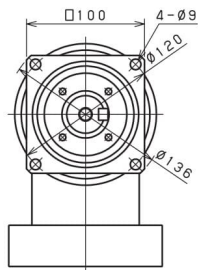

- ※1 적용 모터에 따라 길이는 변경될 수 있습니다.
- ※2 모터 축과 감속기의 입력축 내경이 다를 경우에는 부싱이 삽입됩니다.
- ※1 Length will vary depending on motor.
- ※2 Bushing will be inserted to adapt to motor shaft.

SMES 140 2단 2stage

입력축 내경 Input shaft bore $\leq \phi 28$

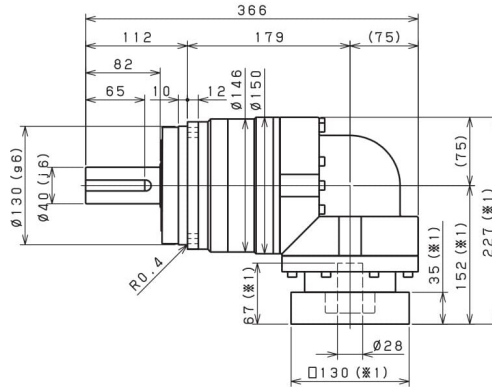
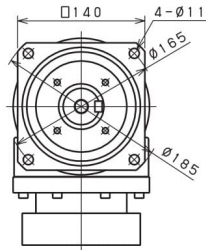

입력축 내경 Input shaft bore $\leq \phi 38$

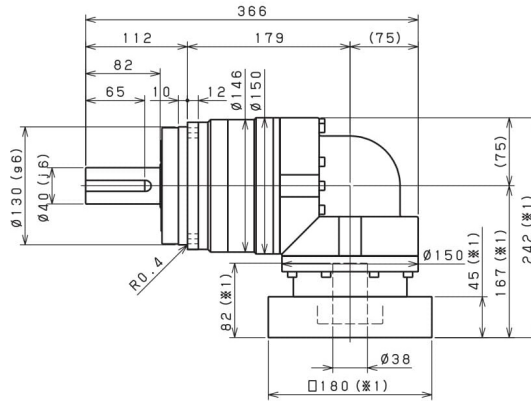
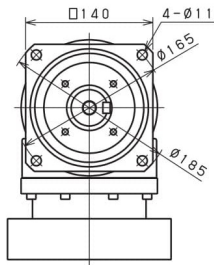

입력축 내경 Input shaft bore $\leq \phi 48$

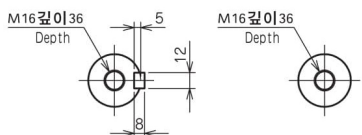
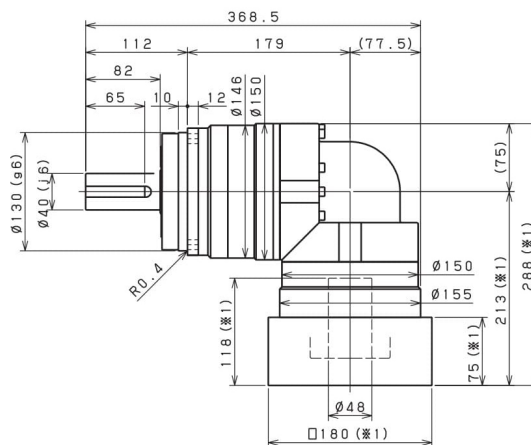
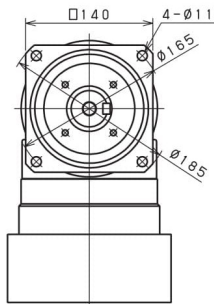

출력축 (KEY타입)
Shaft with key

출력축 (KEY없음)
Smooth shaft

- ※ 1 적용 모터에 따라 길이는 변경될 수 있습니다.
- ※ 2 모터 축과 감속기의 입력축 내경이 다를 경우에는 부싱이 삽입됩니다.
- ※ 1 Length will vary depending on motor.
- ※ 2 Bushing will be inserted to adapt to motor shaft.

SMES 140 3단 3stage

입력축 내경 Input shaft bore $\leq \phi 19$

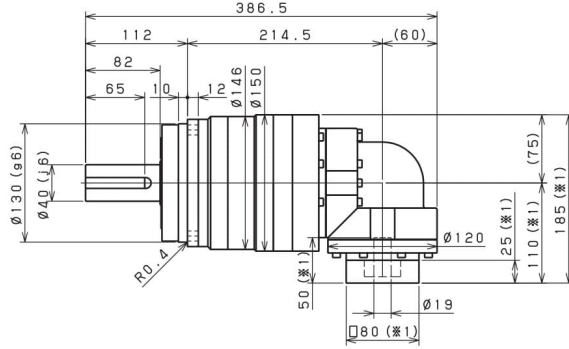
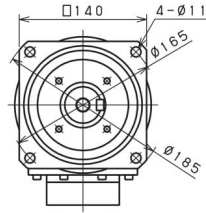

입력축 내경 Input shaft bore $\leq \phi 28$

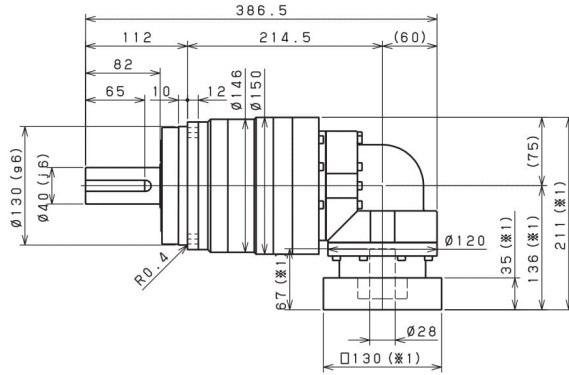
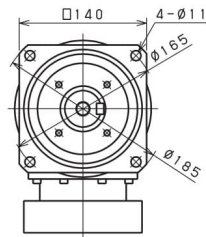

입력축 내경 Input shaft bore $\leq \phi 38$

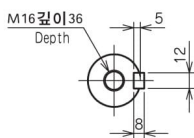
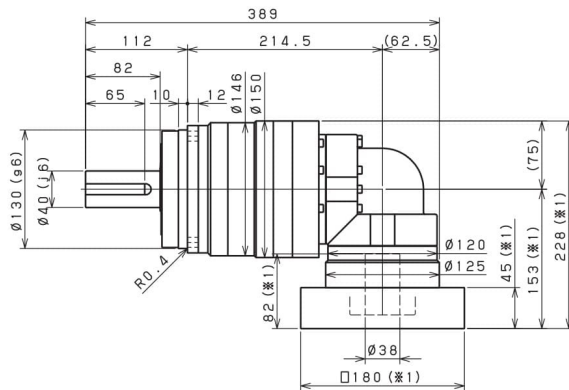
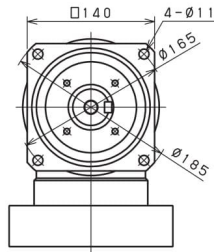

출력축 (KEY타입)
Shaft with key

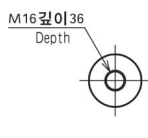

출력축 (KEY없음)
Smooth shaft

- ※1 적용 모터에 따라 길이는 변경될 수 있습니다.
- ※2 모터 축과 감속기의 입력축 내경이 다를 경우에는 부싱이 삽입됩니다.
- ※1 Length will vary depending on motor.
- ※2 Bushing will be inserted to adapt to motor shaft.

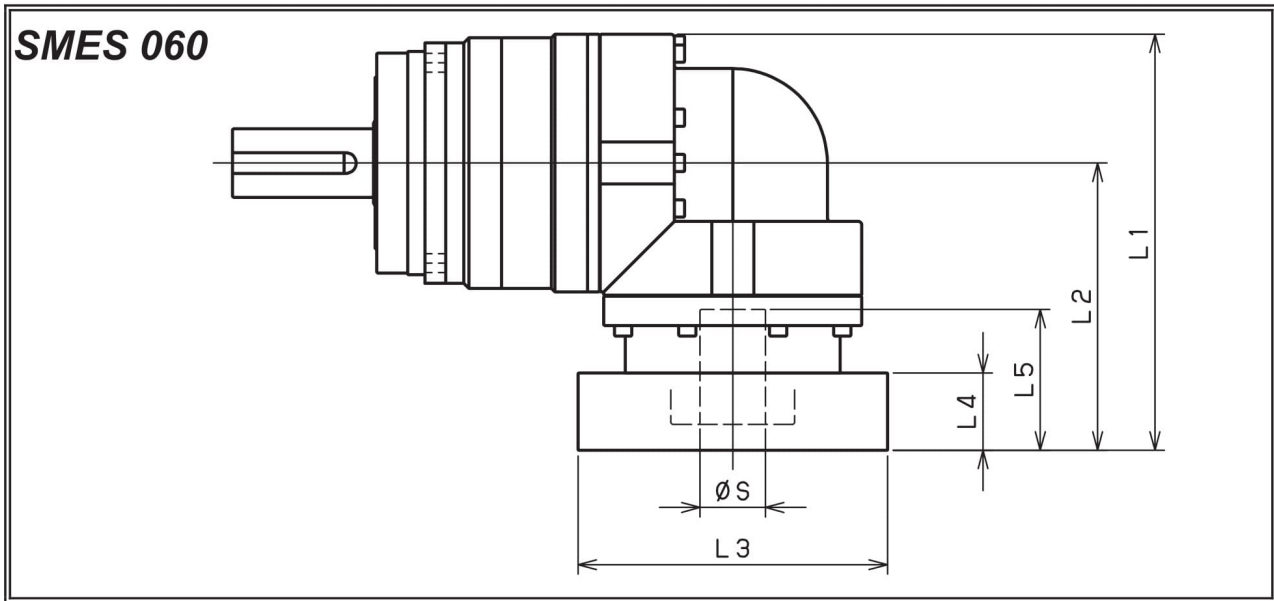

모델명 Model number	** : 어댑터 코드 ** : Adapter code (Mount code)	2단 Double					3단 Triple				
		L1	L2	L3	L4	L5	L1	L2	L3	L4	L5
SMES060□□□-8** (S≤8)	AA·AC·AD·AF·AG	103	71.5	□52	15.5	32	96	64.5	□52	15.5	32
	AB·AE·AH·AJ·AK	108	76.5	□52	20.5	37	101	69.5	□52	20.5	37
	BA·BB·BD·BE	103	71.5	□60	15.5	32	96	64.5	□60	15.5	32
	BC·BF	108	76.5	□60	20.5	37	101	69.5	□60	20.5	37
	CA	108	76.5	□70	20.5	37	101	69.5	□70	20.5	37
SMES060□□□-14** (8<S≤14)	BA·BB·BD·BE·BF·BG·BJ·BK	109	77.5	□65	16.5	35	100	68.5	□65	16.5	35
	BC·BH	114	82.5	□65	21.5	40	105	73.5	□65	21.5	40
	BL	119	87.5	□65	26.5	45	110	78.5	□65	26.5	45
	CA	109	77.5	□70	16.5	35	100	68.5	□70	16.5	35
	CB	114	82.5	□70	21.5	40	105	73.5	□70	21.5	40
	DA·DB·DC·DD·DF·DH	109	77.5	□80	16.5	35	100	68.5	□80	16.5	35
	DE	114	82.5	□80	21.5	40	105	73.5	□80	21.5	40
	DG	119	87.5	□80	26.5	45	110	78.5	□80	26.5	45
	EA·EB·EC	109	77.5	□90	16.5	35	100	68.5	□90	16.5	35
	ED	119	87.5	□90	26.5	45	110	78.5	□90	26.5	45
	FA	109	77.5	□100	16.5	35	100	68.5	□100	16.5	35
	GA	109	77.5	□115	16.5	35	100	68.5	□115	16.5	35
SMES060□□□-19** (14<S≤19)	DA·DB·DC	126	94.5	□80	25	50					
	DD	136	104.5	□80	35	60					
	DE	131	99.5	□80	30	55					
	EA	131	99.5	□90	30	55					
	EB	126	94.5	□90	25	50					
	EC	136	104.5	□90	35	60					
	FA	126	94.5	□100	25	50					
	FB	136	104.5	□100	35	60					
	GA·GC	131	99.5	□115	30	55					
	GB·GD	126	94.5	□115	25	50					
	HA	126	94.5	□130	25	50					
	HB	141	109.5	□130	40	65					
HC·HD·HE	131	99.5	□130	30	55						

※1 2단 감속비: 1/3~1/10 ; 3단 감속비: 1/15~1/100

※2 모터 축과 감속기의 입력축 내경이 다를 경우에는 부싱이 삽입됩니다.

※1 Double reduction : 1/3 ~ 1/10, Triple reduction : 1/15 ~ 1/100

※2 Bushing will be inserted to adapt to motor shaft.

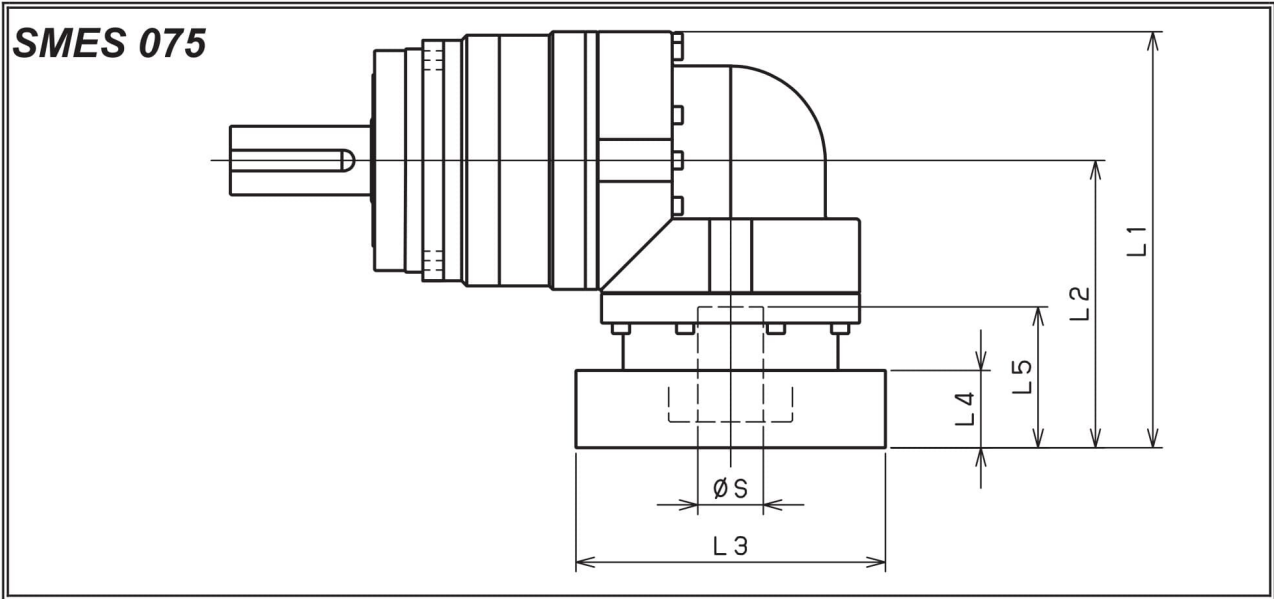

모델명 Model number	** : 어댑터 코드 ** : Adapter code (Mount code)	2단 Double					3단 Triple				
		L1	L2	L3	L4	L5	L1	L2	L3	L4	L5
SMES075□□□-8** (S≤8)	AA·AC·AD·AF·AG	/	/	/	/	/	116	71.5	□52	15.5	32
	AB·AE·AH·AJ·AK	/	/	/	/	/	121	76.5	□52	20.5	37
	BA·BB·BD·BE	/	/	/	/	/	116	71.5	□60	15.5	32
	BC·BF	/	/	/	/	/	121	76.5	□60	20.5	37
	CA	/	/	/	/	/	121	76.5	□70	20.5	37
SMES075□□□-14** (8<S≤14)	BA·BB·BD·BE·BF·BG·BJ·BK	137.5	92	□65	16.5	35	122	77.5	□65	16.5	35
	BC·BH	142.5	97	□65	21.5	40	127	82.5	□65	21.5	40
	BL	147.5	102	□65	26.5	45	132	87.5	□65	26.5	45
	CA	137.5	92	□70	16.5	35	122	77.5	□70	16.5	35
	CB	142.5	97	□70	21.5	40	127	82.5	□70	21.5	40
	DA·DB·DC·DD·DF·DH	137.5	92	□80	16.5	35	122	77.5	□80	16.5	35
	DE	142.5	97	□80	21.5	40	127	82.5	□80	21.5	40
	DG	147.5	102	□80	26.5	45	132	87.5	□80	26.5	45
	EA·EB·EC	137.5	92	□90	16.5	35	122	77.5	□90	16.5	35
	ED	147.5	102	□90	26.5	45	132	87.5	□90	26.5	45
	FA	137.5	92	□100	16.5	35	122	77.5	□100	16.5	35
	GA	137.5	92	□115	16.5	35	122	77.5	□115	16.5	35
SMES075□□□-19** (14<S≤19)	DA·DB·DC	145.5	100	□80	25	50	139	94.5	□80	25	50
	DD	155.5	110	□80	35	60	149	104.5	□80	35	60
	DE	150.5	105	□80	30	55	144	99.5	□80	30	55
	EA	150.5	105	□90	30	55	144	99.5	□90	30	55
	EB	145.5	100	□90	25	50	139	94.5	□90	25	50
	EC	155.5	110	□90	35	60	149	104.5	□90	35	60
	FA	145.5	100	□100	25	50	139	94.5	□100	25	50
	FB	155.5	110	□100	35	60	149	104.5	□100	35	60
	GA·GC	150.5	105	□115	30	55	144	99.5	□115	30	55
	GB·GD	145.5	100	□115	25	50	139	94.5	□115	25	50
	HA	145.5	100	□130	25	50	139	94.5	□130	25	50
	HB	160.5	115	□130	40	65	154	109.5	□130	40	65
	HC·HD·HE	150.5	105	□130	30	55	144	99.5	□130	30	55
SMES075□□□-28** (19<S≤28)	FA·FB·FC	174.5	129	□100	35	67	/	/	/	/	/
	GA·GB·GC·GD·GE·GF·GG	174.5	129	□115	35	67	/	/	/	/	/
	HA·HC·HD	174.5	129	□130	35	67	/	/	/	/	/
	HB	184.5	139	□130	45	77	/	/	/	/	/
	JA·JB·JC	174.5	129	□150	35	67	/	/	/	/	/
	KA·KB	174.5	129	□180	35	67	/	/	/	/	/
	LA	174.5	129	□200	35	67	/	/	/	/	/
MA	174.5	129	□220	35	67	/	/	/	/	/	

※1 2단 감속비: 1/3~1/10 ; 3단 감속비: 1/15~1/100

※1 Double reduction : 1/3 ~ 1/10, Triple reduction : 1/15 ~ 1/100

※2 모터 축과 감속기의 입력축 내경이 다를 경우에는 부싱이 삽입됩니다.

※2 Bushing will be inserted to adapt to motor shaft.

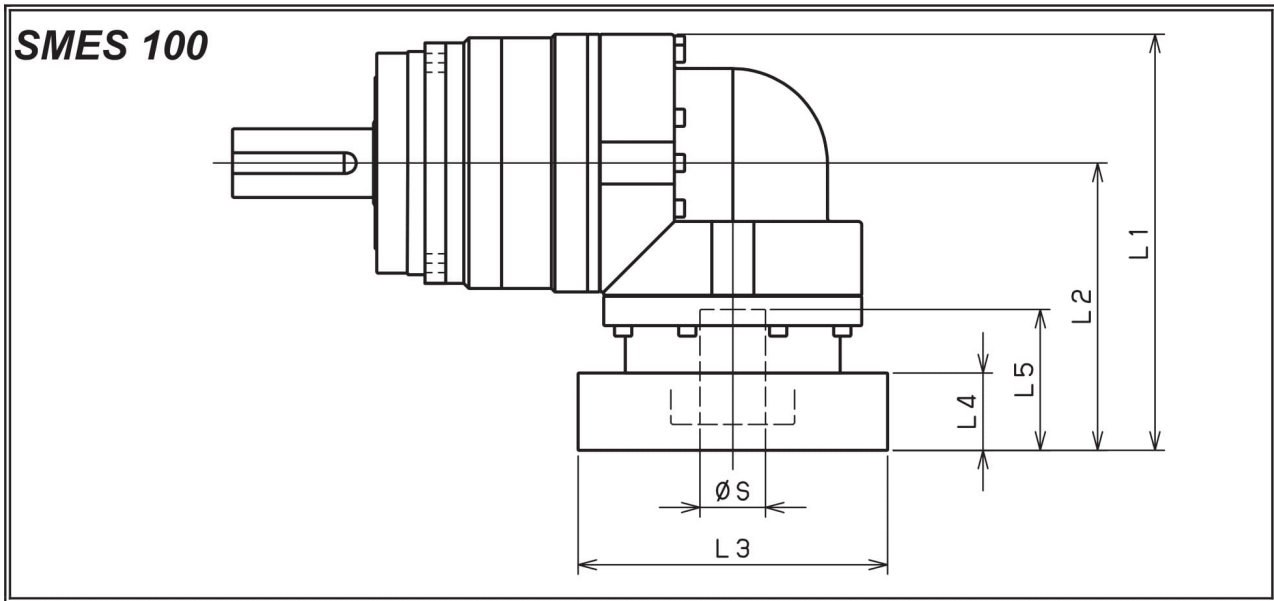

모델명 Model number	** : 어댑터 코드 ** : Adapter code (Mount code)	2단 Double					3단 Triple				
		L1	L2	L3	L4	L5	L1	L2	L3	L4	L5
SMES100□□□-14** (S ≤ 14)	BA·BB·BD·BE·BF·BG·BJ·BK						152	92	□65	16.5	35
	BC·BH						157	97	□65	21.5	40
	BL						162	102	□65	26.5	45
	CA						152	92	□70	16.5	35
	CB						157	97	□70	21.5	40
	DA·DB·DC·DD·DF·DH						152	92	□80	16.5	35
	DE						157	97	□80	21.5	40
	DG						162	102	□80	26.5	45
	EA·EB·EC						152	92	□90	16.5	35
	ED						162	102	□90	26.5	45
	FA						152	92	□100	16.5	35
	GA						152	92	□115	16.5	35
SMES100□□□-19** (14 < S ≤ 19)	DA·DB·DC	170	110	□80	25	50	160	100	□80	25	50
	DD	180	120	□80	35	60	170	110	□80	35	60
	DE	175	115	□80	30	55	165	105	□80	30	55
	EA	175	115	□90	30	55	165	105	□90	30	55
	EB	170	110	□90	25	50	160	100	□90	25	50
	EC	180	120	□90	35	60	170	110	□90	35	60
	FA	170	110	□100	25	50	160	100	□100	25	50
	FB	180	120	□100	35	60	170	110	□100	35	60
	GA·GC	175	115	□115	30	55	165	105	□115	30	55
	GB·GD	170	110	□115	25	50	160	100	□115	25	50
	HA	170	110	□130	25	50	160	100	□130	25	50
	HB	185	125	□130	40	65	175	115	□130	40	65
HC·HD·HE	175	115	□130	30	55	165	105	□130	30	55	
SMES100□□□-28** (19 < S ≤ 28)	FA·FB·FC	196	136	□100	35	67	189	129	□100	35	67
	GA·GB·GC·GD·GE·GF·GG	196	136	□115	35	67	189	129	□115	35	67
	HA·HC·HD	196	136	□130	35	67	189	129	□130	35	67
	HB	206	146	□130	45	77	199	139	□130	45	77
	JA·JB·JC	196	136	□150	35	67	189	129	□150	35	67
	KA·KB	196	136	□180	35	67	189	129	□180	35	67
	LA	196	136	□200	35	67	189	129	□200	35	67
MA	196	136	□220	35	67	189	129	□220	35	67	
SMES100□□□-38** (28 < S ≤ 38)	HA	213	153	□130	45	82					
	HB	208	148	□130	40	77					
	JA	213	153	□150	45	82					
	KA·KB·KC	213	153	□180	45	82					
	LA	213	153	□200	45	82					
	LB	223	163	□200	55	92					
	MA·MB	213	153	□220	45	82					
NA	213	153	□250	45	82						

※1 2단 감속비: 1/3~1/10 ; 3단 감속비: 1/15~1/100

※2 모터 축과 감속기의 입력축 내경이 다를 경우에는 부싱이 삽입됩니다.

※1 Double reduction : 1/3 ~ 1/10, Triple reduction : 1/15 ~ 1/100

※2 Bushing will be inserted to adapt to motor shaft.

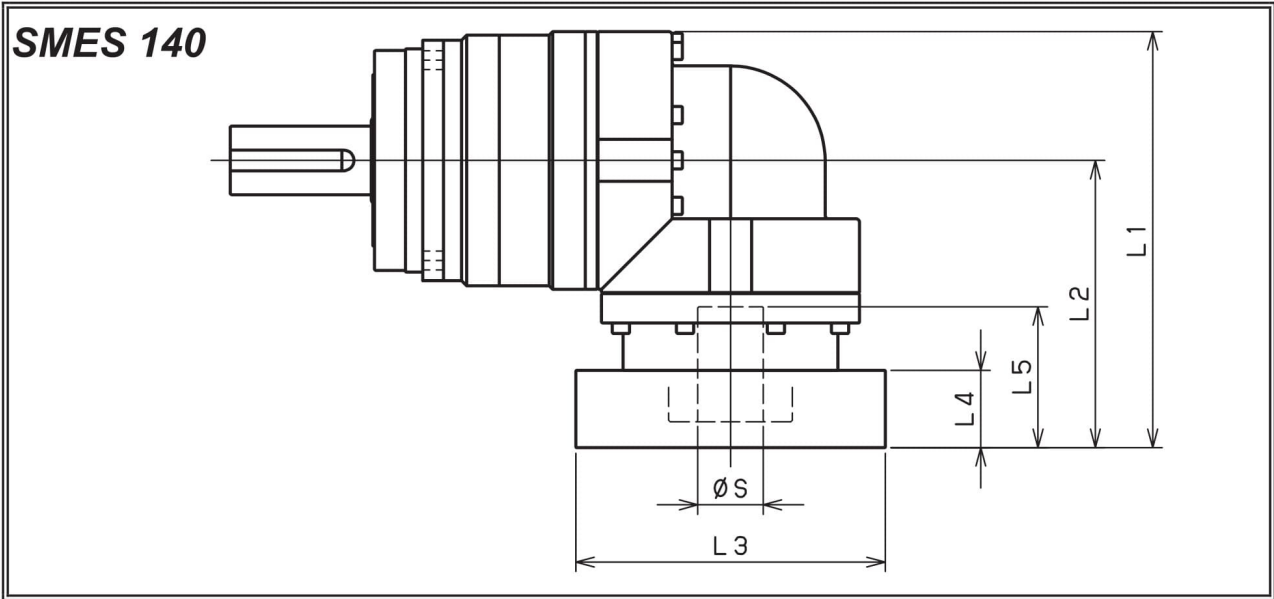

모델명 Model number	** : 어댑터 코드 ** : Adapter code (Mount code)	2단 Double					3단 Triple				
		L1	L2	L3	L4	L5	L1	L2	L3	L4	L5
SMES140□□□-19** (S ≤ 19)	DA·DB·DC	/	/	/	/	/	185	110	□80	25	50
	DD	/	/	/	/	/	195	120	□80	35	60
	DE	/	/	/	/	/	190	115	□80	30	55
	EA	/	/	/	/	/	190	115	□90	30	55
	EB	/	/	/	/	/	185	110	□90	25	50
	EC	/	/	/	/	/	195	120	□90	35	60
	FA	/	/	/	/	/	185	110	□100	25	50
	FB	/	/	/	/	/	195	120	□100	35	60
	GA·GC	/	/	/	/	/	190	115	□115	30	55
	GB·GD	/	/	/	/	/	185	110	□115	25	50
	HA	/	/	/	/	/	185	110	□130	25	50
	HB	/	/	/	/	/	200	125	□130	40	65
HC·HD·HE	/	/	/	/	/	190	115	□130	30	55	
SMES140□□□-28** (19 < S ≤ 28)	FA·FB·FC	227	152	□100	35	67	211	136	□100	35	67
	GA·GB·GC·GD·GE·GF·GG	227	152	□115	35	67	211	136	□115	35	67
	HA·HC·HD	227	152	□130	35	67	211	136	□130	35	67
	HB	237	162	□130	45	77	221	146	□130	45	77
	JA·JB·JC	227	152	□150	35	67	211	136	□150	35	67
	KA·KB	227	152	□180	35	67	211	136	□180	35	67
	LA	227	152	□200	35	67	211	136	□200	35	67
MA	227	152	□220	35	67	211	136	□220	35	67	
SMES140□□□-38** (28 < S ≤ 38)	HA	242	167	□130	45	82	228	153	□130	45	82
	HB	237	162	□130	40	77	223	148	□130	40	77
	JA	242	167	□150	45	82	228	153	□150	45	82
	KA·KB·KC	242	167	□180	45	82	228	153	□180	45	82
	LA	242	167	□200	45	82	228	153	□200	45	82
	LB	252	177	□200	55	92	238	163	□200	55	92
	MA·MB	242	167	□220	45	82	228	153	□220	45	82
NA	242	167	□250	45	82	228	153	□250	45	82	
SMES140□□□-48** (38 < S ≤ 48)	KB·KC	268	193	□180	55	98	/	/	/	/	/
	KA	288	213	□180	75	118	/	/	/	/	/
	LA	268	193	□200	55	98	/	/	/	/	/
	MA	268	193	□220	55	98	/	/	/	/	/
	MB	288	213	□220	75	118	/	/	/	/	/
	NA	288	213	□250	75	118	/	/	/	/	/
PA	288	213	□280	75	118	/	/	/	/	/	

※1 2단 감속비: 1/3~1/10 ; 3단 감속비: 1/15~1/100

※2 모터 축과 감속기의 입력축 내경이 다를 경우에는 부싱이 삽입됩니다.

※1 Double reduction : 1/3 ~ 1/10, Triple reduction : 1/15 ~ 1/100

※2 Bushing will be inserted to adapt to motor shaft.