



프리미엄효율 (Premium Efficiency)

P Series 3-Phase Flange Mounted Type

2.2kW

■ SPECIFICATION

■ MOTOR

프레임 형번 Frame No.	출력 Output (kW)	기종명 Model Name	극수 Poles	전압 Voltage (V)	주파수 Freq. (Hz)	사용 조건 Duty	정격 부하 [Rated Load]					보호 등급 Degrees of protection	절연 등급 Insulation Classification	냉각 방식 Protective Cooling System
							전류 Current (A)	속도 Speed (r/min)	토크 Torque (kgf·cm)	역율 Power Factor(p.u.)	효율 Efficiency (%)			
90L		PPGI220- 2R4F□□	2	220/380	60	CONT.	8.10/4.70	3520	60.9	0.80	87.7	IP55	F	Totally Enclosed Fan-Cooled
		PPGI220- 2U6F□□	2	230/400	50		7.60/4.40	2900	73.9	0.84	85.9			
	460			60	4.4		3490	71.4	0.86	87.2				
100L	2.2	PPQN220- 4R4F□□	4	220/380	60		8.10/4.70	1755	121.4	0.80	89.5			
		PPQN220- 4U6F□□	4	230/400	50		7.80/4.50	1460	146.3	0.78	86.7			
	460			60	4.50		1750	141.6	0.81	89.5				
112M		PPJR220- 6R4F□□	6	220/380	60		10.80/6.30	1175	181.5	0.60	89.6			
		PPJR220- 6U6F□□	6	230/400	50		10.00/5.80	975	219.0	0.61	84.3			
	460			60	5.60		1170	212.0	0.65	89.6				

- Note) • Foot(Leg) Mounted Type 과 Flange Mounted Type 제품은 특성이 동일합니다.
(Foot (Leg) Mounted Type and Flange Mounted Type have the same specifications)
- 전압 U6 모델의 실제 정격출력은 230V/400V 50Hz에서 2.2kW, 460V 60Hz에서 2.55kW입니다.
(Actual rated power for voltage U6 model is 2.2kW at 230V/400V 50Hz and 2.55kW at 460V 60Hz)

■ PE-F Type DIMENSIONS [Flange Mounted Type]

UNIT = mm

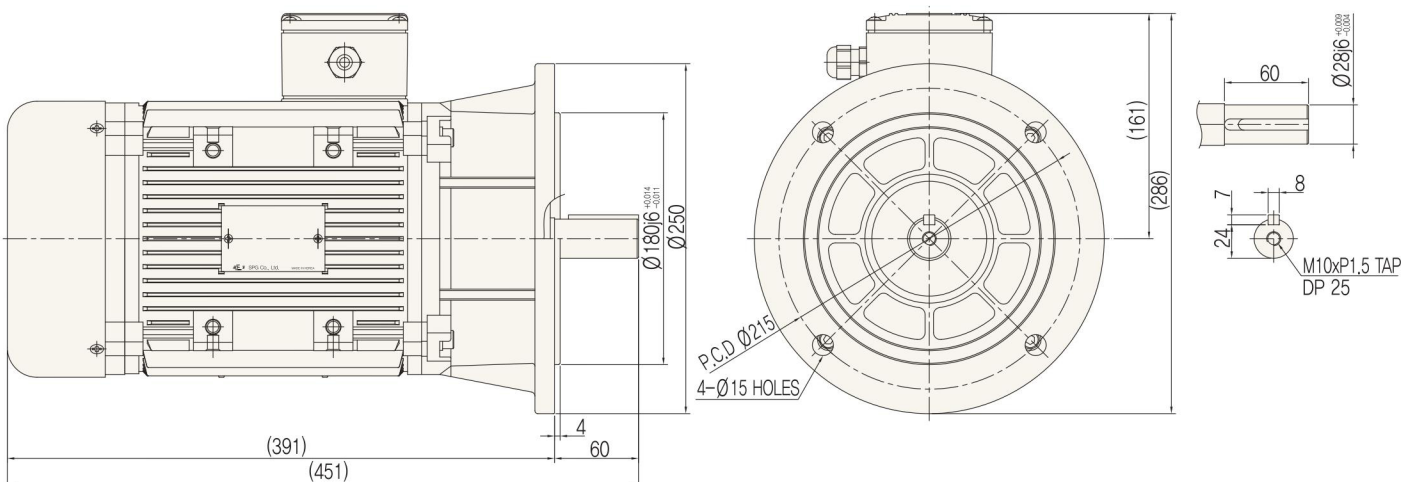

- Note) • 키 및 키홈 공차(Key and Key groove tolerance) : KS B 1311
• 출력축 ØD공차(ØD tolerance for output shaft) : KS B 0401

Bearing No.		Weight
Load	Unload	
6206ZZ	6205ZZ	29.7kg