



프리미엄효율 (Premium Efficiency)

# P Series 3-Phase Foot(Leg) Mounted Type

# 2.2kW

## ■ SPECIFICATION

### ■ MOTOR

| 프레임<br>형번<br>Frame<br>No. | 출력<br>Output<br>(kW) | 기종명<br>Model<br>Name | 극수<br>Poles | 전압<br>Voltage<br>(V) | 주파수<br>Freq.<br>(Hz) | 사용<br>조건<br>Duty | 정격 부하 [Rated Load]   |                        |                          |                             |                         | 보호 등급<br>Degrees<br>of<br>protection | 절연 등급<br>Insulation<br>Classification | 냉각 방식<br>Protective<br>Cooling<br>System |
|---------------------------|----------------------|----------------------|-------------|----------------------|----------------------|------------------|----------------------|------------------------|--------------------------|-----------------------------|-------------------------|--------------------------------------|---------------------------------------|--|
|                           |                      |                      |             |                      |                      |                  | 전류<br>Current<br>(A) | 속도<br>Speed<br>(r/min) | 토크<br>Torque<br>(kgf-cm) | 역율<br>Power<br>Factor(p.u.) | 효율<br>Efficiency<br>(%) |                                      |                                       |  |
| 90L                       |                      | PPGI220-<br>2R4L□□   | 2           | 220/380              | 60                   | CONT.            | 8.10/4.70            | 3520                   | 60.9                     | 0.80                        | 87.7                    | IP55                                 | F                                     | Totally<br>Enclosed<br>Fan-Cooled        |
|                           |                      |                      |             |                      |                      |                  | 7.60/4.40            | 2900                   | 73.9                     | 0.84                        | 85.9                    |                                      |                                       |  |
|                           |                      |                      |             |                      |                      |                  | 4.4                  | 3490                   | 71.4                     | 0.86                        | 87.2                    |                                      |                                       |  |
| 100L                      | 2.2                  | PPHQ220-<br>4R4L□□   | 4           | 220/380              | 60                   | CONT.            | 8.10/4.70            | 1755                   | 121.4                    | 0.80                        | 89.5                    |                                      |                                       |  |
|                           |                      |                      |             |                      |                      |                  | 7.80/4.50            | 1460                   | 146.3                    | 0.78                        | 86.7                    |                                      |                                       |  |
|                           |                      |                      |             |                      |                      |                  | 4.50                 | 1750                   | 141.6                    | 0.81                        | 89.5                    |                                      |                                       |  |
| 112M                      |                      | PPJR220-<br>6R4L□□   | 6           | 220/380              | 60                   | CONT.            | 10.80/6.30           | 1175                   | 181.5                    | 0.60                        | 89.6                    |                                      |                                       |  |
|                           |                      |                      |             |                      |                      |                  | 10.00/5.80           | 975                    | 219.0                    | 0.61                        | 84.3                    |                                      |                                       |  |
|                           |                      |                      |             |                      |                      |                  | 5.60                 | 1170                   | 212.0                    | 0.65                        | 89.6                    |                                      |                                       |  |

- Note) • Foot(Leg) Mounted Type 과 Flange Mounted Type 제품은 특성이 동일합니다.  
(Foot (Leg) Mounted Type and Flange Mounted Type have the same specifications)  
• 전압 U6 모델의 실제 정격출력은 230V/400V 50Hz에서 2.2kW, 460V 60Hz에서 2.55kW입니다.  
(Actual rated power for voltage U6 model is 2.2kW at 230V/400V 50Hz and 2.55kW at 460V 60Hz)

## ■ PE-L Type DIMENSIONS [ Foot(Leg) Mounted Type ]

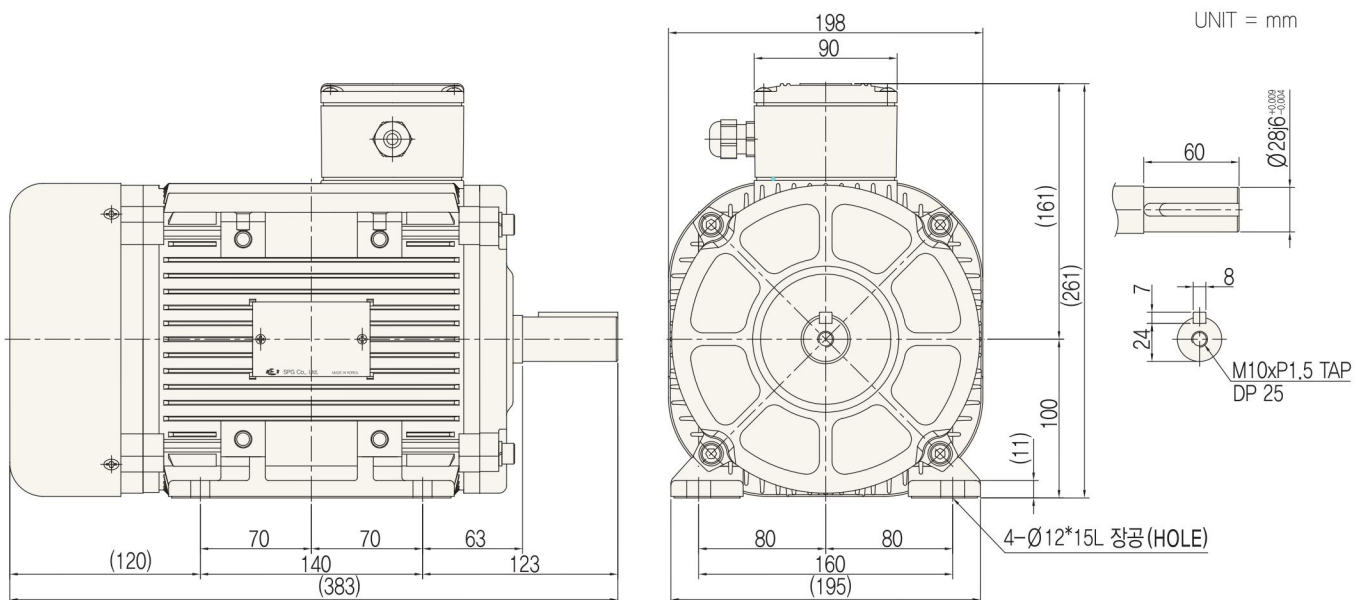

UNIT = mm

- Note) • 키 및 키홈 공차(Key and Key groove tolerance) : KS B 1311  
• 제품의 전체 높이 치수는 분리형 다리(Foot)의 부착 위치에 따라 달라집니다.  
(The total length of the products may vary depending on the mounting position of the discrete foot.)  
• 출력축 ØD공차(ØD tolerance for output shaft) : KS B 0401

| Bearing No. |        | Weight |
|-------------|--------|--------|
| Load        | Unload |        |
| 6206ZZ      | 6205ZZ | 27.4kg |