



150W

INDUCTION MOTOR □ 90mm LEAD WIRE TYPE

SIZE mm sq.	Type	Poles	Output (W)	Voltage (V)	Frequency (Hz)	Duty	Rated Load				Starting Torque		Capacitor (uF)
							Current (A)	Speed (rpm)	Torque (kg-cm) (N-m)		(kg-cm)	(N-m)	
90	S9I150GU S9I150GUCE	4	150	3 ∅ 200	50	Cont.	1.0	1250	11.70	1.170	18.0	1.800	—
					60		0.9	1500	9.70	0.970	15.0	1.500	
	S9I150GT S9I150GTCE	4	150	3 ∅ 220	50	Cont.	1.0	1300	11.30	1.130	22.0	2.200	—
					60		0.9	1550	9.40	0.940	19.0	1.900	
	S9I150GS S9I150GSCE	4	150	3 ∅ 380	50	Cont.	0.46	1250	11.70	1.170	18.00	1.800	—
					60		0.42	1500	9.70	0.970	15.00	1.500	
				3 ∅ 400	50	Cont.	0.49	1250	11.70	1.170	19.00	1.900	
					60		0.43	1500	9.70	0.970	16.00	1.600	

- ❖ 상기 MODEL은 TP가 내장된 THERMALLY PROTECTED TYPE입니다. (CE marked at the end of model name indicates that it is thermally protected type which has received CE with built-in TP.)
- ❖ 기종명 맨 끝자리에 CE가 명기된 MODEL의 인증 관련 내용은 SPG 규격 인증품 현황을 참고하여 주십시오. (TP marked at the end of the model name indicates that it is standard motor with Thermal Protector mounted.)
- ❖ 'H' Type 전용으로 기종명에 표시하지 않습니다. (Only "H" type is applicable.)
- ❖ 삼상 380V~440V모터에서는 인버터 사용을 주의하여 주십시오. 인버터 사용시 권선의 절연이 열화되어 모터가 파손될 수 있습니다. (For a three-phase 380V~440V motor, be cautious when using the inverter. When inverter is used, the insulation of winding becomes hot and may cause damage to motor.)

50Hz

MODEL	GEAR RATIO	3	3.6	5	6	7.5	9	10	12.5	15	18	20	25	30	36	40	50	60	75	90	100	120	150	180	200
	rpm	500	416	300	250	200	166	150	120	100	83	75	60	50	41	37	30	25	20	16	15	12	10	8	7.5
S9KH□B	kg-cm	23.1	27.7	38.5	46.2	57.7	69.3	77.0	86.6	104	125	139	156	187	224	249	300	300	300	300	300	300	300	300	300
	N·m	2.264	2.717	3.773	4.528	5.660	6.792	7.546	8.489	10.24	12.29	13.65	15.36	18.34	21.97	24.42	29.42	29.42	29.42	29.42	29.42	29.42	29.42	29.42	29.42

60Hz

MODEL	GEAR RATIO	3	3.6	5	6	7.5	9	10	12.5	15	18	20	25	30	36	40	50	60	75	90	100	120	150	180	200
	rpm	600	500	360	300	240	200	180	144	120	100	90	72	60	50	45	36	30	24	20	18	15	12	10	9
S9KH□B	kg-cm	23.2	27.8	38.7	46.4	58.0	69.6	77.4	87.0	104	125	139	156	188	225	250	300	300	300	300	300	300	300	300	300
	N·m	2.276	2.731	3.793	4.552	5.689	6.827	7.586	8.534	10.24	12.29	13.65	15.36	18.43	22.06	24.52	29.42	29.42	29.42	29.42	29.42	29.42	29.42	29.42	29.42

- ❖ GEAR HEAD 품명중 □은 감속비를 표시합니다. (The code in □ of gearhead model is for gear ratio.)
- ❖ GEAR HEAD와 조합한 경우의 허용 TORQUE입니다. (It is the permissible TORQUE of the assembled motor and gearhead.)
- ❖ 회전방향은 ■색이 MOTOR의 회전방향과 동일방향이고, 기타는 MOTOR 회전방향과 반대방향입니다. (■ color indicates that the output shaft of the geared motor rotates in the same direction as the output shaft of the motor. Others indicate rotation in the opposite direction.)
- ❖ 회전수는 MOTOR의 동기 회전수(50Hz : 1500rpm, 60Hz : 1800rpm)를 기준으로 하여 감속비로 나누어서 계산하였습니다. 실제의 회전수는 부하의 크기에 따라서 표시된 수치보다 2~20% 적습니다. (Rpm is based on synchronous speed (50Hz: 1500rpm, 60Hz: 1800rpm) divided by gear ratio. The actual rotation speed can be 2~20% less than displayed value depending on the load.)
- ❖ 'H' Type 전용으로 기종명에 표시하지 않습니다. (Only "H" type is applicable.)

DIMENSIONS

+ GEARED MOTOR

- ※ MOTOR MODEL : S9I150G□
- ※ HEAD MODEL : S9□H3B~S9□H200B

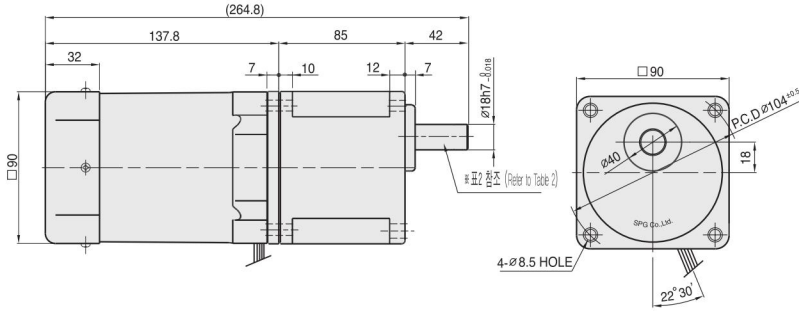

+ MOTOR

- ※ MODEL : S9I150□□

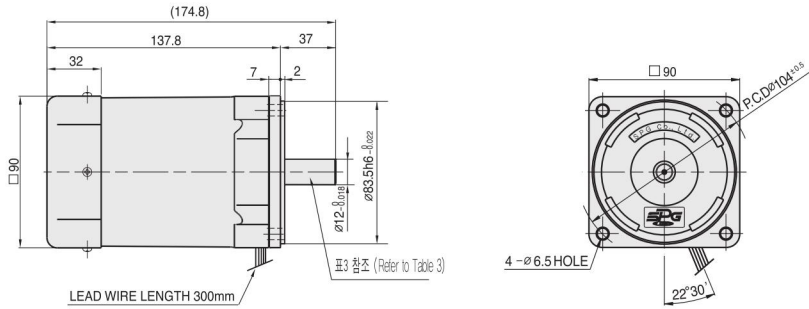

+ WEIGHT - (표1 (Table1))

PART		WEIGHT(kg)
MOTOR		2.93
GEAR HEAD	S9□H3B ~S9□H10B	1.65
	S9□H12.5B ~S9□H20B	1.80
	S9□H25B ~S9□H60B	1.90
	S9□H75B ~S9□H200B	1.95

+ KEY SPEC

GEAR HEAD		MOTOR	

+ GEAR HEAD 출력축 사양 (SPEC for output shaft of gearhead) - (표2 (Table2))

MODEL	출력축 구분 (TYPES OF OUTPUT SHAFT)
STRAIGHT TYPE	
S9SH3B ~S9SH200B	
D-CUT TYPE	
S9DH3B ~S9DH200B	
KEY TYPE	
S9KH3B ~S9KH200B	

+ MOTOR 출력축 사양 (SPEC for output shaft of motor) - (표3 (Table3))

MODEL	출력축 구분 (TYPES OF OUTPUT SHAFT)
GEAR TYPE	
S9I150G□	
STRAIGHT TYPE	
S9I150S□	
D-CUT TYPE	
S9I150D□	
KEY TYPE	
S9I150K□	

SCHEMATIC DIAGRAMS

회전방향은 MOTOR의 SHAFT 끝쪽에서 볼 때의 회전방향입니다. (The direction of motor rotation is as viewed from the front shaft end of the motor.)

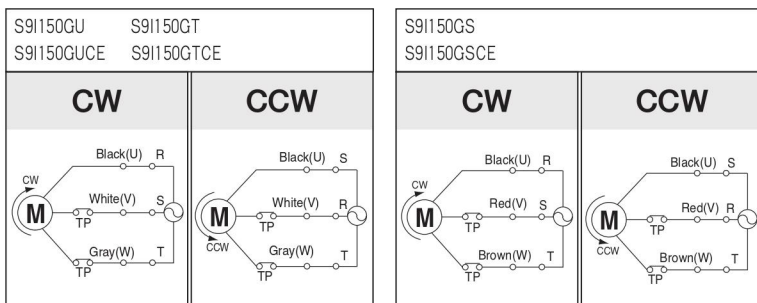

주의 : MOTOR 회전 방향의 교환은 MOTOR가 완전히 정지한 후에 실시하여 주십시오. MOTOR가 회전 중에 회전방향을 교환할 경우 회전방향이 바뀌지 않거나 회전방향이 바뀌어지는 데 있어서 시간이 걸리는 수도 있습니다. (Change the direction of motor rotation only after the motor stops completely. If an attempt is made to change the direction of rotation while the motor is running, the motor may ignore the reversing command or change its direction of rotation after some delay.)



180W

INDUCTION MOTOR □ 90mm LEAD WIRE TYPE

SIZE mm sq.	Type	Poles	Output (W)	Voltage (V)	Frequency (Hz)	Duty	Rated Load				Starting Torque		Capacitor (uF)
							Current (A)	Speed (rpm)	Torque (kg-cm) (N-m)		(kg-cm)	(N-m)	
90	S9I180GA S9I180GA(TP) S9I180GACE	4	180	1 ∅ 110	60	Cont.	2.60	1600	11.50	1.150	8.00	0.800	25.0
	S9I180GB S9I180GB(TP) S9I180GBCE	4	180	1 ∅ 220	60	Cont.	1.32	1600	11.50	1.150	8.00	0.800	6.5
	S9I180GC S9I180GC(TP) S9I180GCCE	4	180	1 ∅ 100	50	Cont.	3.20	1250	14.00	1.400	7.00	0.700	25.0
	60				2.90		1550	11.60	1.160				
	S9I180GD S9I180GD(TP) S9I180GDCE	4	180	1 ∅ 200	50	Cont.	1.60	1250	14.00	1.400	7.00	0.700	6.5
	60				1.45		1550	11.60	1.160				

- ❖ 기종명 맨 끝자리에 (TP)가 명기된 MODEL은 일반 MOTOR의 TP가 내장된 THERMALLY PROTECTED TYPE입니다. (TP marked at the end of the model name indicates that it is standard motor with Thermal Protector mounted.)
- ❖ 'H' Type 전용으로 기종명에 표시하지 않습니다. (Only "H" type is applicable.)

50Hz

MODEL	GEAR RATIO	3	3.6	5	6	7.5	9	10	12.5	15	18	20	25	30	36	40	50	60	75	90	100	120	150	180	200
		rpm	500	416	300	250	200	166	150	120	100	83	75	60	50	41	37	30	25	20	16	15	12	10	8
S9KH□B	kg-cm	34.0	41.0	57.0	68.0	85.1	102	113	128	153	184	204	230	278	300	300	300	300	300	300	300	300	300	300	300
	N·m	3.336	4.021	5.590	6.672	8.341	10.01	11.12	12.55	15.01	18.04	20.02	22.56	27.26	29.42	29.42	29.42	29.42	29.42	29.42	29.42	29.42	29.42	29.42	29.42

60Hz

MODEL	GEAR RATIO	3	3.6	5	6	7.5	9	10	12.5	15	18	20	25	30	36	40	50	60	75	90	100	120	150	180	200
		rpm	600	500	360	300	240	200	180	144	120	100	90	72	60	50	45	36	30	24	20	18	15	12	10
S9KH□B	kg-cm	28.1	34.0	47.0	57.0	71.0	84.2	94.0	105	126	152	168	189	227	273	300	300	300	300	300	300	300	300	300	300
	N·m	2.756	3.334	4.609	5.590	6.963	8.257	9.218	10.30	12.39	14.91	16.51	18.58	22.29	26.75	29.42	29.42	29.42	29.42	29.42	29.42	29.42	29.42	29.42	29.42

- ❖ GEAR HEAD 품명중 □은 감속비를 표시합니다. (The code in □ of gearhead model is for gear ratio.)
- ❖ GEAR HEAD와 조합한 경우의 허용 TORQUE입니다. (It is the permissible torque of the assembled motor and gearhead.)
- ❖ 회전방향은 ■색이 MOTOR의 회전방향과 동일방향이고, 기타는 MOTOR 회전방향과 반대방향입니다. (■ color indicates that the output shaft of the geared motor rotates in the same direction as the output shaft of the motor. Others indicate rotation in the opposite direction.)
- ❖ 회전수는 MOTOR의 동기 회전수(50Hz : 1500rpm, 60Hz : 1800rpm)를 기준으로 하여 감속비로 나누어서 계산하였습니다. 실제의 회전수는 부하의 크기에 따라서 표시된 수치보다 2~20% 적습니다. (Rpm is based on synchronous speed (50Hz: 1500rpm, 60Hz: 1800rpm) divided by gear ratio. The actual rotation speed can be 2~20% less than displayed value depending on the load.)
- ❖ 'H' Type 전용으로 기종명에 표시하지 않습니다. (Only "H" type is applicable.)

DIMENSIONS

+ GEARED MOTOR

- * MOTOR MODEL : S9I180G□
- * HEAD MODEL : S9□H3B~S9□H200B

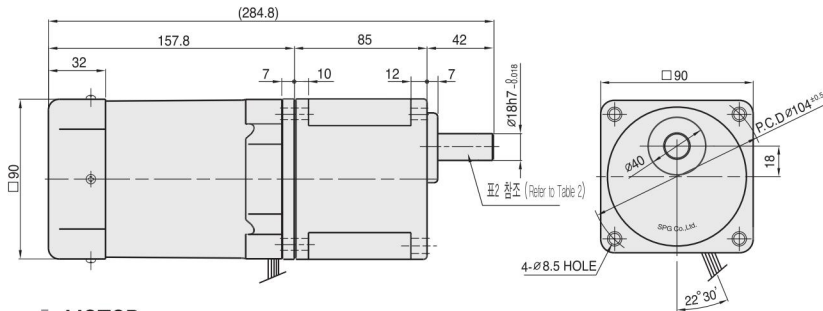

+ MOTOR

- * MOTOR MODEL : S9I180□□

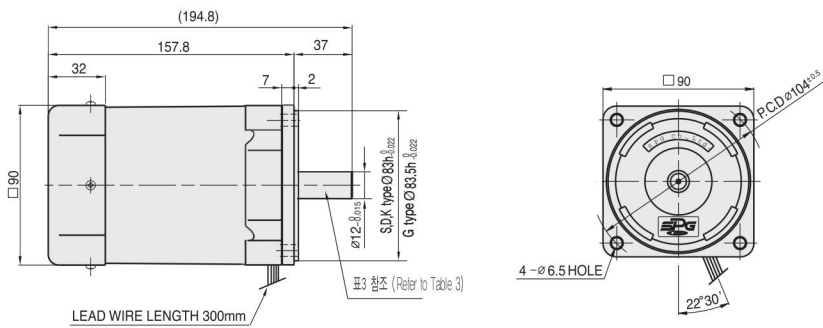

+ WEIGHT - (표1 (Table1))

PART		WEIGHT(kg)
MOTOR		3.70
GEAR HEAD	S9□H3B ~S9□H10B	1.65
	S9□H12.5B ~S9□H20B	1.80
	S9□H25B ~S9□H60B	1.90
	S9□H75B ~S9□H200B	1.95

+ KEY SPEC

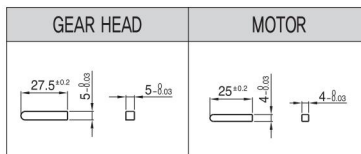

+ GEAR HEAD 출력축 사양 (SPEC for output shaft of gearhead) - (표2 (Table2))

MODEL	출력축 구분 (TYPES OF OUTPUT SHAFT)
STRAIGHT TYPE	
S9SH3B ~S9SH200B	
D-CUT TYPE	
S9DH3B ~S9DH200B	
KEY TYPE	
S9KH3B ~S9KH200B	

+ MOTOR 출력축 사양 (SPEC for output shaft of motor) - (표3 (Table3))

MODEL	출력축 구분 (TYPES OF OUTPUT SHAFT)
GEAR TYPE	
S9I180G□	
STRAIGHT TYPE	
S9I180S□	
D-CUT TYPE	
S9I180D□	
KEY TYPE	
S9I180K□	

SCHEMATIC DIAGRAMS

회전방향은 MOTOR의 SHAFT 끝쪽에서 볼 때의 회전방향입니다. (The direction of motor rotation is as viewed from the front shaft end of the motor.)

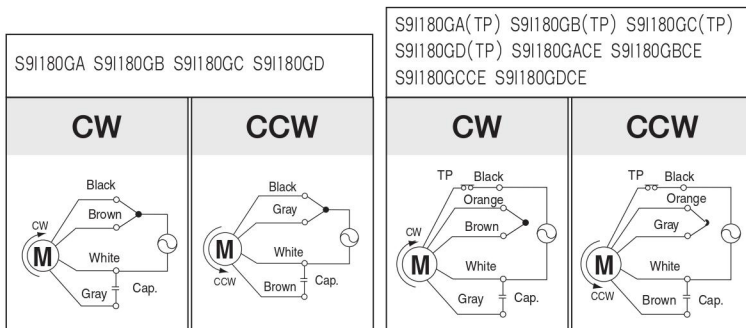

주의 : MOTOR 회전 방향의 교환은 MOTOR가 완전히 정지한 후에 실시하여 주십시오. MOTOR가 회전 중에 회전방향을 교환할 경우 회전방향이 바뀌지 않거나 회전방향이 바뀌어지는 데 있어서 시간이 걸리는 수도 있습니다. (Change the direction of motor rotation only after the motor stops completely. If an attempt is made to change the direction of rotation while the motor is running, the motor may ignore the reversing command or change its direction of rotation after some delay.)



200W

INDUCTION MOTOR □ 90mm LEAD WIRE TYPE

SIZE mm sq.	Type	Poles	Output (W)	Voltage (V)	Frequency (Hz)	Duty	Rated Load				Starting Torque		Capacitor (uF)
							Current (A)	Speed (rpm)	Torque (kg-cm) (N-m)		(kg-cm)	(N-m)	
90	S9I200GU S9I200GUCE	4	200	3 ∅ 200	50	Cont.	1.3	1250	16.00	1.600	24.00	2.400	—
					60		1.2	1500	13.40	1.340	20.00	2.000	
	S9I200GT S9I200GTCE	4	200	3 ∅ 220	50	Cont.	1.3	1300	15.00	1.500	30.00	3.000	—
					60		1.2	1550	12.90	1.290	25.00	2.500	
	S9I200GS S9I200GSCE	4	200	3 ∅ 380	50	Cont.	0.62	1250	16.00	1.600	26.00	2.600	—
					60		0.55	1500	13.40	1.340	22.00	2.200	
				3 ∅ 400	50	Cont.	0.64	1250	16.00	1.600	30.00	3.000	—
					60		0.55	1500	13.40	1.340	25.00	2.500	

- ❖ 상기 MODEL은 TP가 내장된 THERMALLY PROTECTED TYPE입니다. (TP marked at the end of the model name indicates that it is standard motor with Thermal Protector mounted.)
- ❖ 'H' Type 전용으로 기종명에 표시하지 않습니다. (Only "H" type is applicable.)
- ❖ 삼상 380V~440V 모터에서는 인버터 사용을 주의하여 주십시오. 인버터 사용시 권선의 절연이 열화되어 모터가 파손될 수 있습니다. (For a three-phase 380V~440V motor, be cautious when using the inverter. When inverter is used, the insulation of winding becomes hot and may cause damage to motor.)

50Hz

GEAR RATIO	GEAR RATIO																								
	3	3.6	5	6	7.5	9	10	12.5	15	18	20	25	30	36	40	50	60	75	90	100	120	150	180	200	
MODEL	rpm	500	416	300	250	200	166	150	120	100	83	75	60	50	41	37	30	25	20	16	15	12	10	8	7.5
	kg-cm	39.0	47.0	64.8	77.8	97.2	117	130	146	175	210	233	262	300	300	300	300	300	300	300	300	300	300	300	300
S9KH□B	N·m	3.813	4.609	6.355	7.626	9.532	11.47	12.75	14.32	17.16	20.59	22.88	25.74	29.42	29.42	29.42	29.42	29.42	29.42	29.42	29.42	29.42	29.42	29.42	29.42

60Hz

GEAR RATIO	GEAR RATIO																								
	3	3.6	5	6	7.5	9	10	12.5	15	18	20	25	30	36	40	50	60	75	90	100	120	150	180	200	
MODEL	rpm	600	500	360	300	240	200	180	144	120	100	90	72	60	50	45	36	30	24	20	18	15	12	10	9
	kg-cm	32.0	38.3	53.3	64.0	79.9	96.0	107	120	144	173	192	216	259	300	300	300	300	300	3000	300	300	300	300	300
S9KH□B	N·m	3.134	3.760	5.223	6.267	7.384	9.414	10.49	11.75	14.10	16.97	18.83	21.18	25.40	29.42	29.42	29.42	29.42	29.42	29.42	29.42	29.42	29.42	29.42	29.42

- ❖ GEAR HEAD 품명중 □은 감속비를 표시합니다. (The code in □ of gearhead model is for gear ratio.)
- ❖ GEAR HEAD와 조립한 경우의 허용 TORQUE입니다. (It is the permissible torque of the assembled motor and gearhead.)
- ❖ 회전방향은 ■색이 MOTOR의 회전방향과 동일방향이고, 기타는 MOTOR 회전방향과 반대방향입니다. (■ color indicates that the output shaft of the geared motor rotates in the same direction as the output shaft of the motor. Others indicate rotation in the opposite direction.)
- ❖ 회전수는 MOTOR의 동기 회전수(50Hz : 1500rpm, 60Hz : 1800rpm)를 기준으로 하여 감속비로 나누어서 계산하였습니다. 실제의 회전수는 부하의 크기에 따라서 표시된 수치보다 2~20% 적습니다. (Rpm is based on synchronous speed (50Hz: 1500rpm, 60Hz: 1800rpm) divided by gear ratio. The actual rotation speed can be 2~20% less than displayed value depending on the load.)
- ❖ 'H' Type 전용으로 기종명에 표시하지 않습니다. (Only "H" type is applicable.)

DIMENSIONS

GEARED MOTOR

- MOTOR MODEL : S9I200G□
- HEAD MODEL : S9□H3B~S9□H200B

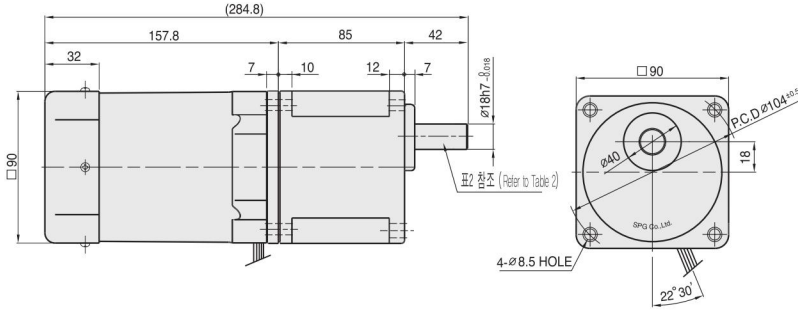

MOTOR

- MOTOR MODEL : S9I200□□

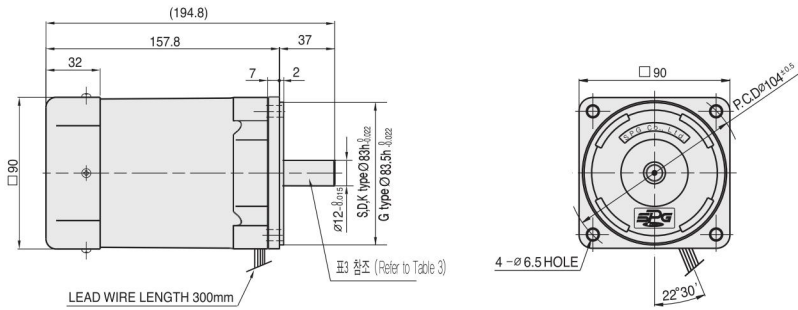

WEIGHT - (표1 (Table1))

PART		WEIGHT(kg)
MOTOR		3.70
GEAR HEAD	S9□H3B ~S9□H10B	1.65
	S9□H12.5B ~S9□H20B	1.80
	S9□H25B ~S9□H60B	1.90
	S9□H75B ~S9□H200B	1.95

KEY SPEC

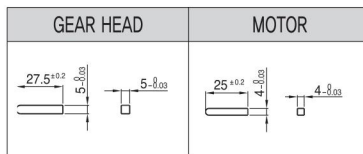

GEAR HEAD 출력축 사양 (SPEC for output shaft of gearhead) - (표2 (Table2))

MODEL	출력축 구분 (TYPES OF OUTPUT SHAFT)
STRAIGHT TYPE S9SH3B ~S9SH200B	
D-CUT TYPE S9DH3B ~S9DH200B	
KEY TYPE S9KH3B ~S9KH200B	

MOTOR 출력축 사양 (SPEC for output shaft of motor) - (표3 (Table3))

MODEL	출력축 구분 (TYPES OF OUTPUT SHAFT)
GEAR TYPE S9I200G□	
D-CUT TYPE S9I200D□	
KEY TYPE S9I200K□	

SCHEMATIC DIAGRAMS

회전방향은 MOTOR의 SHAFT 끝쪽에서 볼 때의 회전방향입니다. (The direction of motor rotation is as viewed from the front shaft end of the motor.)

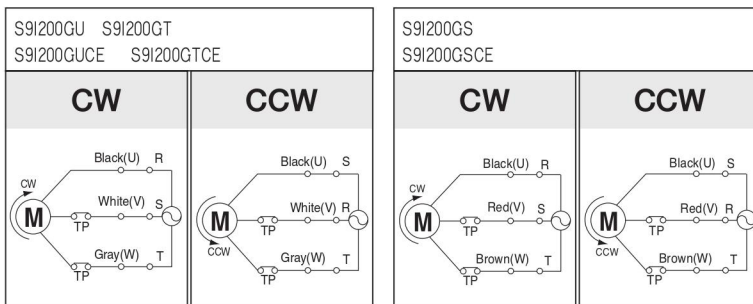

주의 : MOTOR 회전 방향의 교환은 MOTOR가 완전히 정지한 후에 실시하여 주십시오. MOTOR가 회전 중에 회전방향을 교환할 경우 회전방향이 바뀌지 않거나 회전방향이 바뀌어지는 데 있어서 시간이 걸리는 수도 있습니다. (Change the direction of motor rotation only after the motor stops completely. If an attempt is made to change the direction of rotation while the motor is running, the motor may ignore the reversing command or change its direction of rotation after some delay.)