



60W

E · S MOTOR □ 90mm LEAD WIRE TYPE

SPECIFICATION OF SR TYPE SPEED CONTROL MOTORS

SIZE mm sq.	Motor Type	Controller Type	Poles	Output (w)	Voltage (V)	Freq. (Hz)	Duty	Speed Range (rpm)	Permissible Torque				Starting Torque		Cap. (μF)
									at 1200rpm		at 90rpm		(kg-cm)	(N-m)	
90	S9R60GA( )-ES12 S9R60GA( )-ES12CE	SRA02 SRA02CE	4	60	1 ∅ 110	60	30min.	90-1700	5.50	0.550	3.92	0.392	6.10	0.610	25.0
	S9R60GB( )-ES12 S9R60GB( )-ES12CE	SRB02 SRB02CE	4	60	1 ∅ 220	60	30min.	90-1700	5.50	0.550	3.92	0.392	6.10	0.610	6.0
	S9R60GC( )-ES12 S9R60GC( )-ES12CE	SRC02 SRC02CE	4	60	1 ∅ 100	50 60	30min.	90-1400 90-1700	5.11 4.42	0.511 0.442	3.61	0.361	6.04	0.604	25.0
	S9R60GD( )-ES12 S9R60GD( )-ES12CE	SRD02 SRD02CE	4	60	1 ∅ 200	50 60	30min.	90-1400 90-1700	5.11 4.42	0.511 0.442	3.61	0.361	6.04	0.604	6.0
	S9R60GX( )-ES12 S9R60GX( )-ES12CE	SRX02 SRX02CE	4	60	1 ∅ 220 1 ∅ 240	50	30min.	90-1400	5.25 5.90	0.525 0.590	3.01 3.25	0.301 0.325	6.02 6.32	0.602 0.632	5.0

- 기종명 맨 끝자리에 (TP)가 명기된 MOTOR MODEL은 일반 MOTOR의 TP가 내장된 THERMALLY PROTECTED TYPE입니다. 또한 기종명 S9R60GX-ES12는 TP가 내장된 THERMALLY PROTECTED TYPE입니다. (TP marked at the end of the motor model name indicates that it is standard motor with Thermal Protector mounted S9R60GX-ES12 is thermally protected type with TP mounted.)
- ( )는 L, H Type를 표시합니다. L은 GEAR HEAD의 L과, H는 GEAR HEAD의 H와 사용하여 주십시오. (( ) is for marking 'L' type or 'H'. 'L' should be used with gearhead 'L' and 'H' should be used with gearhead 'H'. )

50Hz

GEAR RATIO	3 3.6 5 6 7.5 9 10 12.5 15 18 20 25 30 36 40 50 60 75 90 100 120 150 180 200																				
	MODEL	rpm	kg-cm	N-m																	
S9KC□( )	rpm	500	12.2	1.196 1.431 1.989 2.381 2.989 3.577 3.969 4.469 5.370 6.439 7.154 8.085 9.702 11.66 12.94 16.17 19.40 19.60 19.60 19.60 19.60 19.60 19.60 19.60 19.60																	
S9KC□( )-S	N-m	1.196	1.431	1.989 2.381 2.989 3.577 3.969 4.469 5.370 6.439 7.154 8.085 9.702 11.66 12.94 16.17 19.40 19.60 19.60 19.60 19.60 19.60 19.60 19.60 19.60 19.60 19.60																	

60Hz

GEAR RATIO	3 3.6 5 6 7.5 9 10 12.5 15 18 20 25 30 36 40 50 60 75 90 100 120 150 180 200																				
	MODEL	rpm	kg-cm	N-m																	
S9KC□( )	rpm	600	9.72	0.953 1.147 1.588 1.901 2.381 2.862 3.175 3.577 4.292 5.155 5.723 6.468 7.762 9.310 10.39 12.94 15.48 17.35 19.60 19.60 19.60 19.60 19.60 19.60 19.60 19.60																	
S9KC□( )-S	N-m	0.953	1.147	1.588 1.901 2.381 2.862 3.175 3.577 4.292 5.155 5.723 6.468 7.762 9.310 10.39 12.94 15.48 17.35 19.60 19.60 19.60 19.60 19.60 19.60 19.60 19.60																	

- GEAR HEAD 품명 중 □은 감속비를 표시합니다. (The code in □ of gearhead model is for gear ratio. )
- GEAR HEAD와 조합한 경우의 허용 TORQUE입니다. (It is the permissible TORQUE of the assembled motor and gearhead.)
- 감속비 1/10의 중간 GEAR HEAD를 접속한 경우의 허용 TORQUE는 200kg-cm입니다. (The permissible torque of the motor and inter-decimal gearhead is 200 kg-cm.)
- 회전방향은 색이 MOTOR의 회전방향과 동일방향이고, 기타는 MOTOR 회전방향과 반대방향입니다. ( color indicates that the output shaft of the geared motor rotates in the same direction as the output shaft of the motor. Others indicate rotation in the opposite direction. )
- 회전수는 MOTOR의 동기 회전수(50Hz : 1500rpm, 60Hz : 1800rpm)를 기준으로 하여 감속비로 나누어서 계산하였습니다. 실제의 회전수는 부하의 크기에 따라서 표시된 수치보다 2~20% 적습니다. (Rpm is based on synchronous speed (50Hz: 1500rpm, 60Hz: 1800rpm) divided by gear ratio. The actual rotation speed can be 2~20% less than displayed value depending on the load.)
- ( )는 L, H Type를 표시합니다. L은 MOTOR의 L과, H는 MOTOR의 H와 사용하여 주십시오. (( ) is for marking 'L' type or 'H'. 'L' should be used with motor 'L' and 'H' should be used with motor 'H'. )

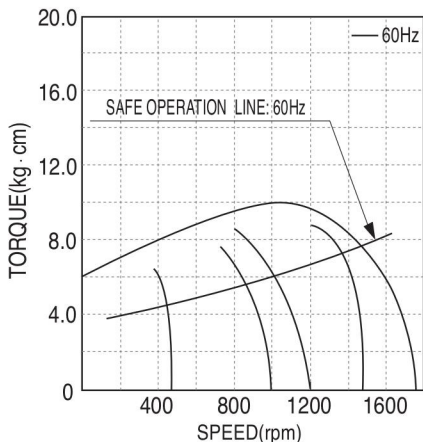

▲ S9R60GA( )-ES12 S9R60GB( )-ES12  
S9R60GA( )-ES12(TP) S9R60GB( )-ES12(TP)

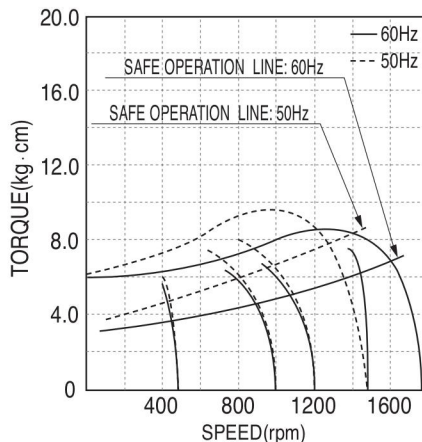

▲ S9R60GC( )-ES12 S9R60GD( )-ES12  
S9R60GC( )-ES12(TP) S9R60GD( )-ES12(TP)

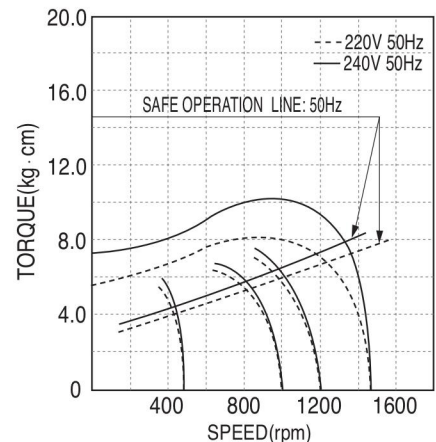

▲ S9R60GX( )-ES12

# DIMENSIONS

## + GEARED MOTOR

- \* MOTOR MODEL : S9R60G□□-ES12
- \* HEAD MODEL : S9□C3B□~S9□C200B□-S

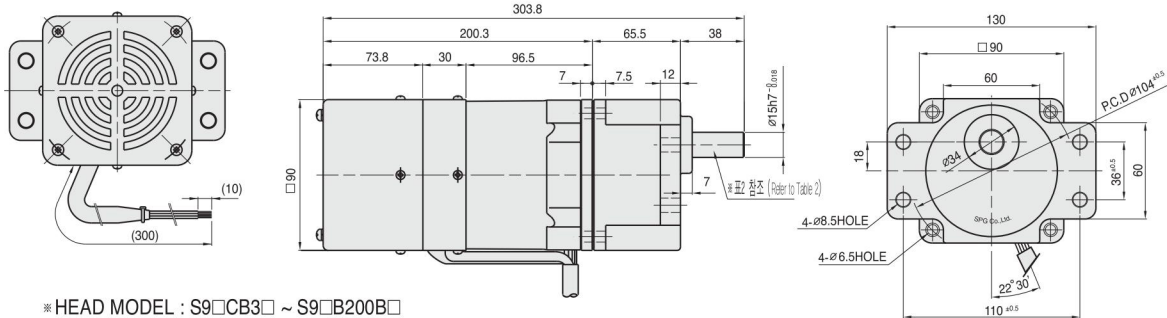

- \* HEAD MODEL : S9□CB3□ ~ S9□B200B□

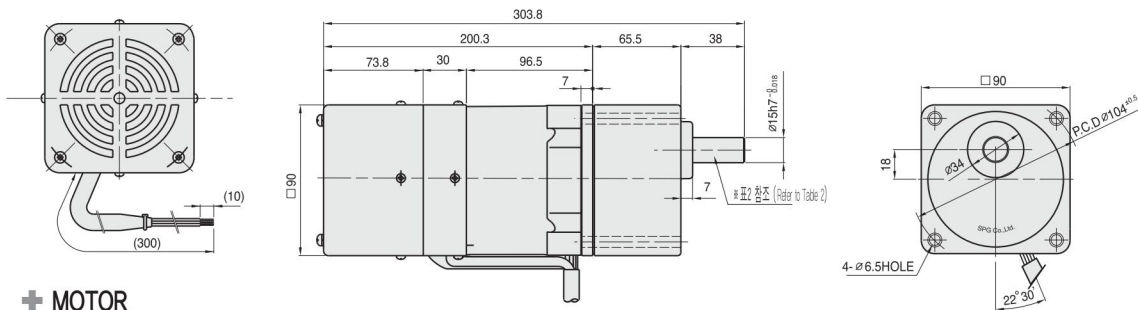

## + MOTOR

- \* MOTOR MODEL : S9R60□□□-ES12

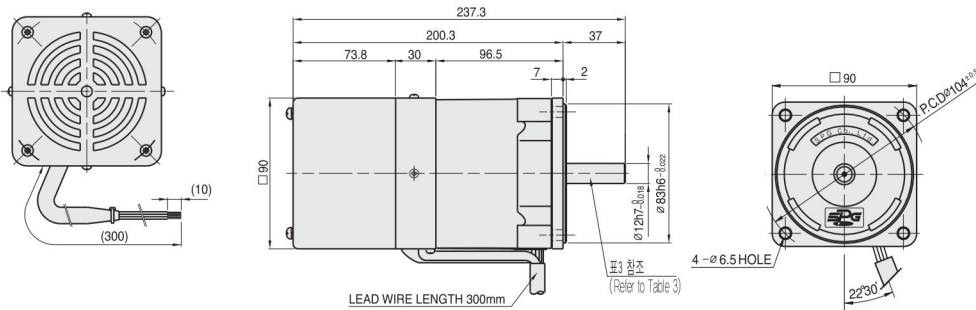

## + INTER-DECIMAL GEAR HEAD

- \* MODEL : S9GX10B(H,L)

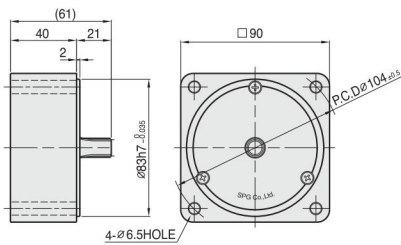

## + WEIGHT - (표1 Table1)

PART	WEIGHT(kg)	
MOTOR	3,45	
DECIMAL GEAR HEAD	0,65	
GEAR HEAD	S9□C3B□ ~S9□C10B□	1,21
	S9□C12.5B□ ~S9□C20B□	1,30
	S9□C25B□ ~S9□C60B□	1,40
	S9□C75B□ ~S9□C200B□	1,45

## + GEAR HEAD 출력축 사양 (SPEC for output shaft of gearhead) - (표2 Table2)

MODEL	출력축 구분 (TYPES OF OUTPUT SHAFT)
S9SC3B□ ~S9SC200B□	STRAIGHT TYPE
	D-CUT TYPE
S9SDC3B□ ~S9SDC200B□	STRAIGHT TYPE
	D-CUT TYPE
S9KC3B□ ~S9KC200B□	STRAIGHT TYPE
	KEY TYPE

## + KEY SPEC

GEAR HEAD	MOTOR

## + MOTOR 출력축 사양 (SPEC for output shaft of motor) - (표3 Table3)

MODEL	출력축 구분 (TYPES OF OUTPUT SHAFT)
S9R60G□-ES12	GEAR TYPE
	STRAIGHT TYPE
S9R60S□-ES12	GEAR TYPE
	D-CUT TYPE
S9R60D□-ES12	GEAR TYPE
	KEY TYPE
S9R60K□-ES12	KEY TYPE

# DIMENSIONS

## GEARED MOTOR

\* MOTOR MODEL : S9R60G□H-ES12  
 \* HEAD MODEL : S9□D3B□~S9□D200B

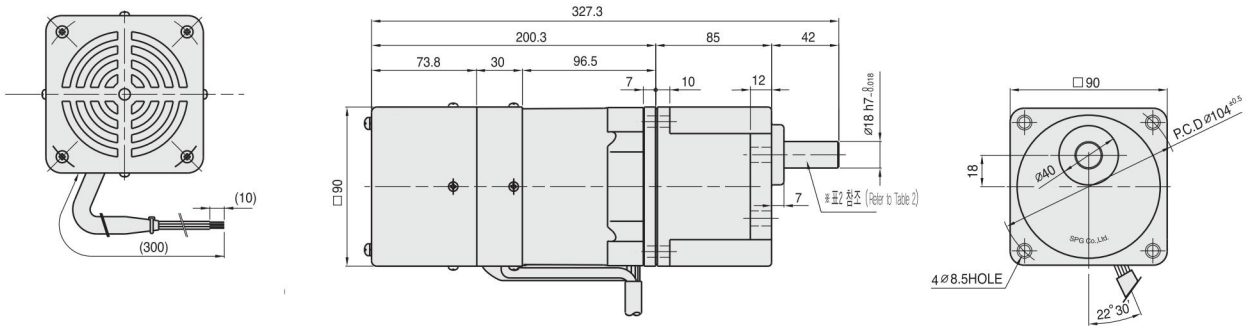

## WEIGHT - (표1 (Table1))

PART	WEIGHT(kg)	
MOTOR	3.45	
DECIMAL GEAR HEAD	1.65	
GEAR HEAD	S9□D3B□ ~S9□D10B□	1.65
	S9□D12.5B□ ~S9□D20B□	1.80
	S9□D25B□ ~S9□D60B□	1.90
	S9□D75B□ ~S9□D200B□	1.95

## KEY SPEC

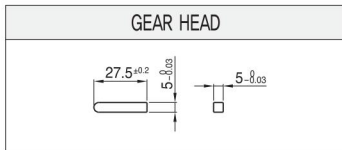

## GEAR HEAD 출력축 사양 (SPEC for output shaft of gearhead) - (표2 (Table2))

MODEL	출력축 구분 (TYPES OF OUTPUT SHAFT)
STRAIGHT TYPE	
S9SD3B□ ~S9SD200B□	
D-CUT TYPE	
S9DD3B□ ~S9DD200B□	
KEY TYPE	
S9KD3B□ ~S9KD200B□	

## 50Hz

MODEL	GEAR RATIO	3	3.6	5	6	7.5	9	10	12.5	15	18	20	25	30	36	40	50	60	75	90	100	120	150	180	200
	S9KD□B	rpm	500	416	300	250	200	166	150	120	100	83	75	60	50	41	37	30	25	20	16	15	12	10	8
kg-cm		12.2	14.6	20.3	24.3	30.4	36.5	40.5	45.6	54.8	65.7	73.0	82.5	99.0	119	132	165	198	221	266	295	300	300	300	300
	N·m	1.196	1.431	1.989	2.381	2.989	3.577	3.969	4.469	5.370	6.439	7.154	8.085	9.702	11.66	12.94	16.17	19.40	21.67	26.09	28.93	29.42	29.42	29.42	29.42

## 60Hz

MODEL	GEAR RATIO	3	3.6	5	6	7.5	9	10	12.5	15	18	20	25	30	36	40	50	60	75	90	100	120	150	180	200
	S9KD□B	rpm	600	500	360	300	240	200	180	144	120	100	90	72	60	50	45	36	30	24	20	18	15	12	10
kg-cm		9.72	11.7	16.2	19.4	24.3	29.2	32.4	36.5	43.8	52.6	58.4	66.0	79.2	95.0	106	132	158	177	212	236	283	300	300	300
	N·m	0.953	1.147	1.588	1.901	2.381	2.862	3.175	3.577	4.292	5.155	5.723	6.468	7.762	9.310	10.39	12.94	15.48	17.35	20.79	23.14	27.75	29.42	29.42	29.42

- \* GEAR HEAD 품명 중 □는 감속비를 표시합니다. (The code in □ of gearhead model is for gear ratio.)
- \* GEAR HEAD와 조합한 경우의 허용 TORQUE입니다. ( It is the permissible torque of the assembled motor and gearhead.)
- \* 감속비 1/10의 중간 GEAR HEAD를 접속한 경우의 허용 TORQUE는 300kg-cm입니다. (The permissible torque of the motor and inter-decimal gearhead is 300 kg-cm.)
- \* 회전방향은 ■ 색이 MOTOR의 회전방향과 동일방향이고, 기타는 MOTOR 회전방향과 반대방향입니다. ( ■ color indicates that the output shaft of the geared motor rotates in the same direction as the output shaft of the motor. Others indicate rotation in the opposite direction. )
- \* 회전수는 MOTOR의 동기 회전수(50Hz : 1500rpm, 60Hz : 1800rpm)를 기준으로 하여 감속비로 나누어서 계산하였습니다. 실제의 회전수는 부하의 크기에 따라서 표시된 수치보다 2~20% 적습니다. (Rpm is based on synchronous speed (50Hz: 1500rpm, 60Hz: 1800rpm) divided by gear ratio. The actual rotation speed can be 2~20% less than displayed value depending on the load.)
- \* 'h' Type 전용으로 기종명에 표시하지 않습니다. MOTOR의 H와 사용하여 주십시오. (Only "h" type is applicable.)