



25W

E · S MOTOR □ 80mm LEAD WIRE TYPE

SPECIFICATION OF SR TYPE SPEED CONTROL MOTORS

SIZE mm sq.	Motor Type	Controller Type	Poles	Output (W)	Voltage (V)	Freq. (Hz)	Duty	Speed Range (rpm)	Permissible Torque				Starting Torque		Cap. (μ F)		
									at 1200rpm		at 90rpm		(kg-cm)	(N-m)		(kg-cm)	(N-m)
									(kg-cm)	(N-m)	(kg-cm)	(N-m)					
80	S8R25GA-ES12 S8R25GA-ES12(TP) S8R25GA-ES12CE	SRA02 SRA02CE	4	25	1 ϕ 110	60	30min.	90-1700	2.45	0.245	0.90	0.090	1.90	0.190	10.0		
	S8R25GB-ES12 S8R25GB-ES12(TP) S8R25GB-ES12CE	SRB02 SRB02CE	4	25	1 ϕ 220	60	30min.	90-1700	2.45	0.245	0.90	0.090	1.90	0.190	2.5		
	S8R25GC-ES12 S8R25GC-ES12(TP) S8R25GC-ES12CE	SRC02 SRC02CE	4	25	1 ϕ 100	50 60	30min.	90-1400 90-1700	2.25 2.00	0.225 0.200	0.75	0.075	1.75	0.175	10.0		
	S8R25GD-ES12 S8R25GD-ES12(TP) S8R25GD-ES12CE	SRD02 SRD02CE	4	25	1 ϕ 200	50 60	30min.	90-1400 90-1700	2.25 2.00	0.225 0.200	0.75	0.075	1.75	0.175	2.5		
	S8R25GX-ES12 S8R25GX-ES12CE	SRX02 SRX02CE	4	25	1 ϕ 220 1 ϕ 240	50	30min.	90-1400	2.30 2.45	0.230 0.245	0.75 0.75	0.075 0.075	1.75 1.860	0.175 0.186	2.0		

- 기종명 맨 끝자리에 CE가 명기된 MOTOR MODEL의 인증 관련 내용은 SPG 규격 인증품 현황을 참고하여 주십시오. (CE marked at the end of motor model name indicates that it is thermally protected type which has received CE.)
- 기종명 맨 끝자리에 CE가 명기된 SR TYPE CONTROLLER MODEL의 인증 관련 내용은 SPG 규격 인증품 현황을 참고하여 주십시오. (SR type controller model with "CE" appeared at the end of motor model name indicates that the product acquired CE MARK certification.)
- 기종명 맨 끝자리에 (TP)가 명기된 MOTOR MODEL은 일반 MOTOR의 TP가 내장된 THERMALLY PROTECTED TYPE입니다. 또한 기종명 S8R25GX-ES12, S8R25GX-ES12CE는 TP가 내장된 THERMALLY PROTECTED TYPE입니다. (TP marked at the end of the motor model name indicates that it is standard motor with Thermal Protector mounted, S8R25GX-ES12, S8R25GX-ES12CE is thermally protected type with TP mounted.)
- 'L' Type 전용으로 기종명에 표시하지 않습니다. ("L" or "H" type does not apply to motors under 40W.)

SPECIFICATION OF SS TYPE SPEED CONTROL MOTORS

SIZE mm sq.	Motor Type	Controller Type	Poles	Output (W)	Voltage (V)	Freq. (Hz)	Duty	Speed Range (rpm)	Permissible Torque				Starting Torque		Cap. (μ F)		
									at 1200rpm		at 90rpm		(kg-cm)	(N-m)		(kg-cm)	(N-m)
									(kg-cm)	(N-m)	(kg-cm)	(N-m)					
80	S8R25GA-ES24 S8R25GA-ES24(TP) S8R25GA-ES24CE	SSA02-SRSS SSA03-SRSS	4	25	1 ϕ 110	60	30min.	90-1700	2.45	0.245	0.90	0.090	1.90	0.190	10.0		
	S8R25GB-ES24 S8R25GB-ES24(TP) S8R25GB-ES24CE	SSB02-SRSS SSB03-SRSS	4	25	1 ϕ 220	60	30min.	90-1700	2.45	0.245	0.90	0.090	1.90	0.190	2.5		
	S8R25GC-ES24 S8R25GC-ES24(TP) S8R25GC-ES24CE	SSC02-SRSS SSC03-SRSS	4	25	1 ϕ 100	50 60	30min.	90-1400 90-1700	2.25 2.00	0.225 0.200	0.75	0.075	1.75	0.175	10.0		
	S8R25GD-ES24 S8R25GD-ES24(TP) S8R25GD-ES24CE	SSD02-SRSS SSD03-SRSS	4	25	1 ϕ 200	50 60	30min.	90-1400 90-1700	2.25 2.00	0.225 0.200	0.75	0.075	1.75	0.175	2.5		
	S8R25GX-ES24 S8R25GX-ES24CE	SSX02-SRSS SSX03-SRSS	4	25	1 ϕ 220 1 ϕ 240	50	30min.	90-1400	2.30 2.45	0.230 0.245	0.75 0.75	0.075 0.075	1.75 1.860	0.175 0.186	2.0		

- 기종명 맨 끝자리에 CE가 명기된 MOTOR MODEL의 인증 관련 내용은 SPG 규격 인증품 현황을 참고하여 주십시오. (CE marked at the end of motor model name indicates that it is thermally protected type which has received CE.)
- 기종명 맨 끝자리에 (TP)가 명기된 MOTOR MODEL은 일반 MOTOR의 TP가 내장된 THERMALLY PROTECTED TYPE입니다. 또한 기종명 S8R25GX-ES24, S8R25GX-ES24CE는 TP가 내장된 THERMALLY PROTECTED TYPE입니다. (TP marked at the end of the motor model name indicates that it is standard motor with Thermal Protector mounted, S8R25GX-ES24, S8R25GX-ES24CE is thermally protected type with TP mounted.)
- 'L' Type 전용으로 기종명에 표시하지 않습니다. ("L" or "H" type does not apply to motors under 40W.)

50Hz

GEAR RATIO		3	3.6	5	6	7.5	9	10	12.5	15	18	20	25	30	36	40	50	60	75	90	100	120	150	180	200
MODEL	rpm	500	416	300	250	200	166	150	120	100	83	75	60	50	41	37	30	25	20	16	15	12	10	8	7.5
	kg-cm	5.3	6.4	8.9	10.7	13.4	16.0	17.8	22.3	26.7	32.1	32.1	40.2	48.2	57.8	64.2	72.6	80.0	80.0	80.0	80.0	80.0	80.0	80.0	80.0
S8KA□B	N·m	0.519	0.627	0.872	1.049	1.313	1.568	1.744	2.185	2.617	3.146	3.146	3.940	4.724	5.664	6.292	7.115	7.840	7.840	7.840	7.840	7.840	7.840	7.840	7.840

60Hz

GEAR RATIO		3	3.6	5	6	7.5	9	10	12.5	15	18	20	25	30	36	40	50	60	75	90	100	120	150	180	200
MODEL	rpm	600	500	360	300	240	200	180	144	120	100	90	72	60	50	45	36	30	24	20	18	15	12	10	9
	kg-cm	4.4	5.2	7.3	8.7	10.9	13.1	14.6	18.2	21.9	26.2	26.3	32.9	39.4	47.3	52.6	59.4	71.3	80.0	80.0	80.0	80.0	80.0	80.0	80.0
S8KA□B	N·m	0.431	0.510	0.715	0.853	1.068	1.284	1.431	1.784	2.146	2.568	2.577	3.224	3.861	4.635	5.155	5.821	6.987	7.840	7.840	7.840	7.840	7.840	7.840	7.840

- ❖ GEAR HEAD 품명 중 □은 감속비를 표시합니다. (The code in □ of gearhead model is for gear ratio.)
- ❖ GEAR HEAD와 조합한 경우의 허용 TORQUE입니다. (It is the permissible torque of the assembled motor and gearhead.)
- ❖ 감속비 1/10의 중간 GEAR HEAD를 접속한 경우의 허용 TORQUE는 80kg-cm입니다. (The permissible torque of the motor and inter-decimal gearhead is 80 kg-cm.)
- ❖ 회전방향은 ■색이 MOTOR의 회전방향과 동일방향이고, 기타는 MOTOR 회전방향과 반대방향입니다. (■ color indicates that the output shaft of the geared motor rotates in the same direction as the output shaft of the motor. Others indicate rotation in the opposite direction.)
- ❖ 회전수는 MOTOR의 동기 회전수(50Hz : 1500rpm, 60Hz : 1800rpm)를 기준으로 하여 감속비로 나누어서 계산하였습니다. 실제의 회전수는 부하의 크기에 따라서 표시된 수치보다 2~20% 적습니다. (Rpm is based on synchronous speed (50Hz: 1500rpm, 60Hz: 1800rpm) divided by gear ratio. The actual rotation speed can be 2~20% less than displayed value depending on the load.)
- ❖ 'L' Type 전용으로 기종명에 표시하지 않습니다. ("L" or "H" type does not apply to motors under 40W.)

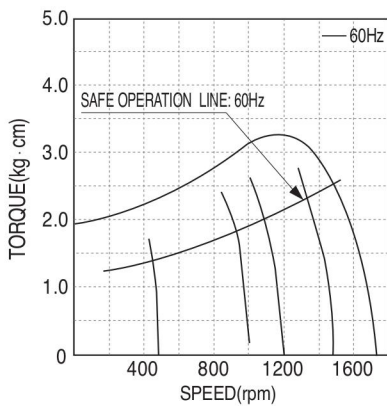

- ▲ S8R25GA-ES12 S8R25GA-ES24
- S8R25GA-ES12(TP) S8R25GA-ES24(TP)
- S8R25GA-ES12CE S8R25GA-ES24CE
- S8R25GB-ES12 S8R25GB-ES24
- S8R25GB-ES12(TP) S8R25GB-ES24(TP)
- S8R25GB-ES12CE S8R25GB-ES24CE

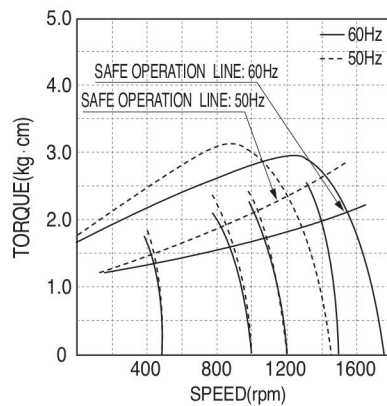

- ▲ S8R25GC-ES12 S8R25GC-ES24
- S8R25GC-ES12(TP) S8R25GC-ES24(TP)
- S8R25GC-ES12CE S8R25GC-ES24CE
- S8R25GD-ES12 S8R25GD-ES24
- S8R25GD-ES12(TP) S8R25GD-ES24(TP)
- S8R25GD-ES12CE S8R25GD-ES24CE

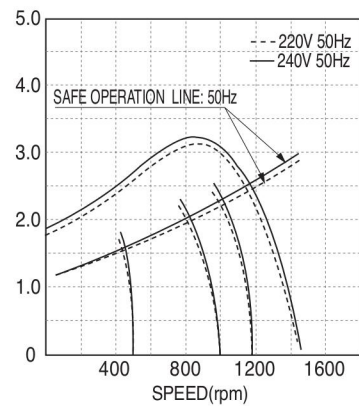

- ▲ S8R25GX-ES12 S8R25GX-ES24
- S8R25GX-ES12CE S8R25GX-ES24CE

DIMENSIONS

+ GEARED MOTOR

* MOTOR MODEL : S8R(15,25)G□-ES12, S8R(15,25)G□-ES24
 * HEAD MODEL : S8□A3□~S8□A200□

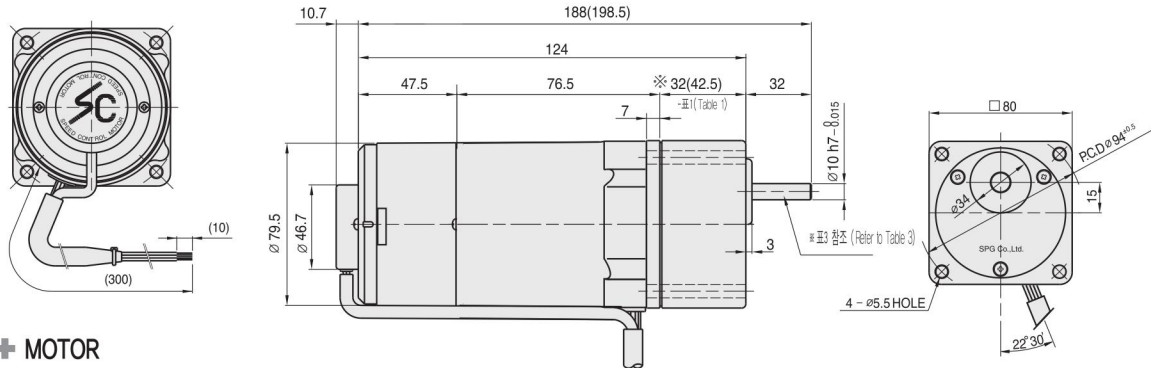

+ MOTOR

* MOTOR MODEL : S8R(15,25)□□-ES12, S8R(15,25)□□-ES24

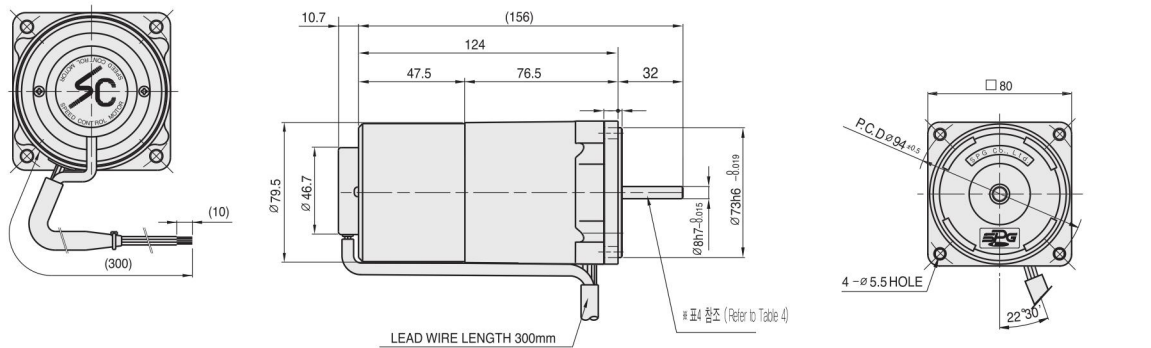

+ INTER-DECIMAL GEAR HEAD

* MODEL : S8GX10B

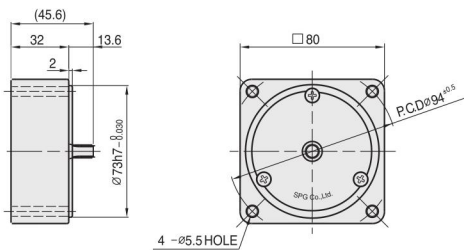

+ ※32(42.5) - (표1 (Table1))

GEAR RATIO	SIZE(mm)
S8□A3□ ~ S8□A18□	32
S8□A20□ ~ S8□A200□	42.5

+ WEIGHT - (표2 (Table2))

PART	WEIGHT(kg)	
15W MOTOR	2.00	
25W MOTOR	2.00	
DECIMAL GEAR HEAD	0.43	
GEAR HEAD	S8□A3□ ~ S8□A18□	0.43
	S8□A20□ ~ S8□A40□	0.57
	S8□A50□ ~ S8□A200□	0.61

+ GEAR HEAD 출력축 사양 (SPEC for output shaft of gearhead) - (표3 (Table3))

MODEL	출력축 구분 (TYPES OF OUTPUT SHAFT)
STRAIGHT TYPE	S8SA3□ ~ S8SA200□
	D-CUT TYPE
KEY TYPE	S8DA3□ ~ S8DA200□
	S8KA3□ ~ S8KA200□

+ KEY SPEC

GEAR HEAD	MOTOR
25 ^{+0.2} 4- $\frac{3}{16}$ _{0.03}	25 ^{+0.2} 3- $\frac{3}{16}$ _{0.025}

+ MOTOR 출력축 사양 (SPEC for output shaft of motor) - (표4 (Table4))

MODEL	출력축 구분 (TYPES OF OUTPUT SHAFT)
GEAR TYPE	S8R15G□-ES12 S8R25G□-ES12 S8R15G□-ES24 S8R25G□-ES24
	STRAIGHT TYPE
	D-CUT TYPE
	KEY TYPE
MOTOR TYPE	S8R15S□-ES12 S8R25S□-ES12 S8R15S□-ES24 S8R25S□-ES24
	STRAIGHT TYPE
	D-CUT TYPE
	KEY TYPE