

SPECIFICATION OF SR TYPE SPEED CONTROL MOTORS

SIZE mm sq.	Motor Type	Controller Type	Poles	Output (W)	Voltage (V)	Freq. (Hz)	Duty	Speed Range (rpm)	Permissible Torque				Starting Torque		Cap. (μF)
									at 1200rpm		at 90rpm		(kg-cm)	(N-m)	
90	S9R40GA()-S12 S9R40GA()-S12(TP) S9R40GA()-S12CE	SRA02 SRA02CE	4	40	1 ∅ 110	60	30min.	90-1700	2.80	0.280	1.10	0.110	3.50	0.350	15.0
	S9R40GB()-S12 S9R40GB()-S12(TP) S9R40GB()-S12CE	SRB02 SRB02CE	4	40	1 ∅ 220	60	30min.	90-1700	2.80	0.280	1.10	0.110	3.50	0.350	4.0
	S9R40GC()-S12 S9R40GC()-S12(TP) S9R40GC()-S12CE	SRC02 SRC02CE	4	40	1 ∅ 100	50 60	30min.	90-1400 90-1700	3.00 2.10	0.300 0.210	1.10	0.110	3.00	0.300	15.0
	S9R40GD()-S12 S9R40GD()-S12(TP) S9R40GD()-S12CE	SRD02 SRD02CE	4	40	1 ∅ 200	50 60	30min.	90-1400 90-1700	3.00 2.10	0.300 0.210	0.95	0.095	3.00	0.300	4.0
	S9R40GX()-S12 S9R40GX()-S12CE	SRX02 SRX02CE	4	40	1 ∅ 220 1 ∅ 240	50	30min.	90-1400	2.50 3.80	0.250 0.380	0.90	0.090	2.90 3.30	0.290 0.330	3.0

- 기종명 맨 끝자리에 CE가 명기된 MOTOR MODEL의 인증 관련 내용은 SPG 규격 인증품 현황을 참고하여 주십시오. (CE marked at the end of motor model name indicates that it is thermally protected type which has received CE.)
- 기종명 맨 끝자리에 CE가 명기된 SR TYPE CONTROLLER MODEL의 인증 관련 내용은 SPG 규격 인증품 현황을 참고하여 주십시오. (SR type controller model with "CE" appeared at the end of motor model name indicates that the product acquired CE MARK certification.)
- 기종명 맨 끝자리에 (TP)가 명기된 MOTOR MODEL은 일반 MOTOR의 TP가 내장된 THERMALLY PROTECTED TYPE입니다. 또한 기종명 S9R40GX-S12, S9R40GX-S12CE는 TP가 내장된 THERMALLY PROTECTED TYPE입니다. (TP marked at the end of the motor model name indicates that it is standard motor with Thermal Protector mounted. S9R40GX-S12, S9R40GX-S12CE is thermally protected type with TP mounted.)
- ()는 L·H TYPE을 포함합니다. L은 GEAR HEAD의 L과, H는 GEAR HEAD의 GEAR HEAD의 H와 사용하여 주십시오. (() is for marking 'L' type or 'H'. 'L' should be used with gearhead 'L' and 'H' should be used with gearhead 'H'.)

SPECIFICATION OF SS TYPE SPEED CONTROL MOTORS

SIZE mm sq.	Motor Type	Controller Type	Poles	Output (W)	Voltage (V)	Freq. (Hz)	Duty	Speed Range (rpm)	Permissible Torque				Starting Torque		Cap. (μF)
									at 1200rpm		at 90rpm		(kg-cm)	(N-m)	
90	S9R40GA()-S24 S9R40GA()-S24(TP) S9R40GA()-S24CE	SSA02-SRSS SSA03-SRSS	4	40	1 ∅ 110	60	30min.	90-1700	2.80	0.280	1.10	0.110	3.50	0.350	15.0
	S9R40GB()-S24 S9R40GB()-S24(TP) S9R40GB()-S24CE	SSB02-SRSS SSB03-SRSS	4	40	1 ∅ 220	60	30min.	90-1700	2.80	0.280	1.10	0.110	3.50	0.350	4.0
	S9R40GC()-S24 S9R40GC()-S24(TP) S9R40GC()-S24CE	SSC02-SRSS SSC03-SRSS	4	40	1 ∅ 100	50 60	30min.	90-1400 90-1700	3.00 2.10	0.300 0.210	1.10	0.110	3.00	0.300	15.0
	S9R40GD()-S24 S9R40GD()-S24(TP) S9R40GD()-S24CE	SSD02-SRSS SSD03-SRSS	4	40	1 ∅ 200	50 60	30min.	90-1400 90-1700	3.00 2.10	0.300 0.210	0.95	0.095	3.00	0.300	4.0
	S9R40GX()-S24 S9R40GX()-S24CE	SSX02-SRSS SSX03-SRSS	4	40	1 ∅ 220 1 ∅ 240	50	30min.	90-1400	2.50 3.80	0.250 0.380	0.90	0.090	2.90 3.30	0.290 0.330	3.0

- 기종명 맨 끝자리에 CE가 명기된 MOTOR MODEL의 인증 관련 내용은 SPG 규격 인증품 현황을 참고하여 주십시오. (CE marked at the end of motor model name indicates that it is thermally protected type which has received CE.)
- 기종명 맨 끝자리에 (TP)가 명기된 MOTOR MODEL은 일반 MOTOR의 TP가 내장된 THERMALLY PROTECTED TYPE입니다. 또한 기종명 S9R40GX-S24, S9R40GX-S24CE는 TP가 내장된 THERMALLY PROTECTED TYPE입니다. (TP marked at the end of the motor model name indicates that it is standard motor with Thermal Protector mounted. S9R40GX-S24, S9R40GX-S24CE is thermally protected type with TP mounted.)
- ()는 L·H TYPE을 포함합니다. L은 GEAR HEAD의 L과, H는 GEAR HEAD의 GEAR HEAD의 H와 사용하여 주십시오. (() is for marking 'L' type or 'H'. 'L' should be used with gearhead 'L' and 'H' should be used with gearhead 'H'.)

50Hz

GEAR RATIO		3	3.6	5	6	7.5	9	10	12.5	15	18	20	25	30	36	40	50	60	75	90	100	120	150	180	200
MODEL	rpm	500	416	300	250	200	166	150	120	100	83	75	60	50	41	37	30	25	20	16	15	12	10	8	7.5
	kg-cm	8.3	9.9	13.8	16.5	20.7	24.8	27.5	34.4	41.3	49.6	49.6	62.1	74.5	89.4	99.3	100	100	100	100	100	100	100	100	100
S9KB□B()	N·m	0.813	0.970	1.352	1.617	2.029	2.430	2.695	3.371	4.047	4.861	4.861	6.086	7.301	8.761	9.731	9.800	9.800	9.800	9.800	9.800	9.800	9.800	9.800	9.800

60Hz

GEAR RATIO		3	3.6	5	6	7.5	9	10	12.5	15	18	20	25	30	36	40	50	60	75	90	100	120	150	180	200
MODEL	rpm	600	500	360	300	240	200	180	144	120	100	90	72	60	50	45	36	30	24	20	18	15	12	10	9
	kg-cm	6.8	8.2	11.3	13.6	17.0	20.4	22.7	28.4	34.0	40.8	40.9	51.1	61.3	73.6	81.8	100	100	100	100	100	100	100	100	100
S9KB□B()	N·m	0.666	0.804	1.107	1.333	1.666	1.999	2.225	2.783	3.332	3.998	4.008	5.008	6.007	7.213	8.016	9.800	9.800	9.800	9.800	9.800	9.800	9.800	9.800	9.800

- ❖ GEAR HEAD 품명 중 □은 감속비를 표시합니다. (The code in □ of gearhead model is for gear ratio.)
- ❖ GEAR HEAD와 조합한 경우의 허용 TORQUE입니다. (It is the permissible torque of the assembled motor and gearhead.)
- ❖ 감속비 1/10의 중간 GEAR HEAD를 접속한 경우의 허용 TORQUE는 100kg-cm입니다. (The permissible torque of the motor and inter-decimal gearhead is 100 kg-cm.)
- ❖ 회전방향은 ■ 색이 MOTOR의 회전방향과 동일방향이고, 기타는 MOTOR 회전방향과 반대방향입니다. (■ color indicates that the output shaft of the geared motor rotates in the same direction as the output shaft of the motor. Others indicate rotation in the opposite direction.)
- ❖ 회전수는 MOTOR의 동기 회전수(50Hz : 1500rpm, 60Hz : 1800rpm)를 기준으로 하여 감속비로 나누어서 계산하였습니다. 실제의 회전수는 부하의 크기에 따라서 표시된 수치보다 2~20% 적습니다. (Rpm is based on synchronous speed (50Hz: 1500rpm, 60Hz: 1800rpm) divided by gear ratio. The actual rotation speed can be 2~20% less than displayed value depending on the load.)
- ❖ ()는 L, H Type을 표시합니다. L은 MOTOR의 L과, H는 MOTOR의 H와 사용하여 주십시오. () is for marking 'L' type or 'H'. 'L' should be used with gearhead 'L' and 'H' should be used with gearhead 'H'.)

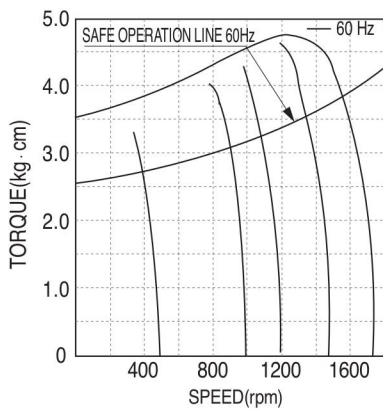

- ▲ S9R40GA()-S12 S9R40GA()-S24
S9R40GA()-S12(TP) S9R40GA()-S24(TP)
S9R40GA()-S12CE S9R40GA()-S24CE
S9R40GB()-S12 S9R40GB()-S24
S9R40GB()-S12(TP) S9R40GB()-S24(TP)
S9R40GB()-S12CE S9R40GB()-S24

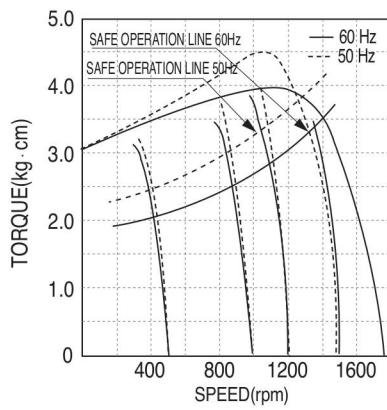

- ▲ S9R40GC()-S12 S9R40GC()-S24
S9R40GC()-S12(TP) S9R40GC()-S24(TP)
S9R40GC()-S12CE S9R40GC()-S24CE
S9R40GD()-S12 S9R40GD()-S24
S9R40GC()-S12 S9R40GC()-S24(TP)
S9R40GD()-S12CE S9R40GD()-S24CE

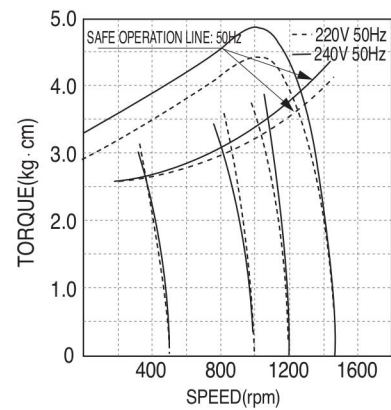

- ▲ S9R40GX()-S12 S9R40GX()-S24
S9R40GX()-S12CE S9R40GX()-S24CE

DIMENSIONS

+ GEARED MOTOR

※ MOTOR MODEL : S9R40G□□-S12, S9R40G□□-S24
 ※ HEAD MODEL : S9□B3□~S9□B200□

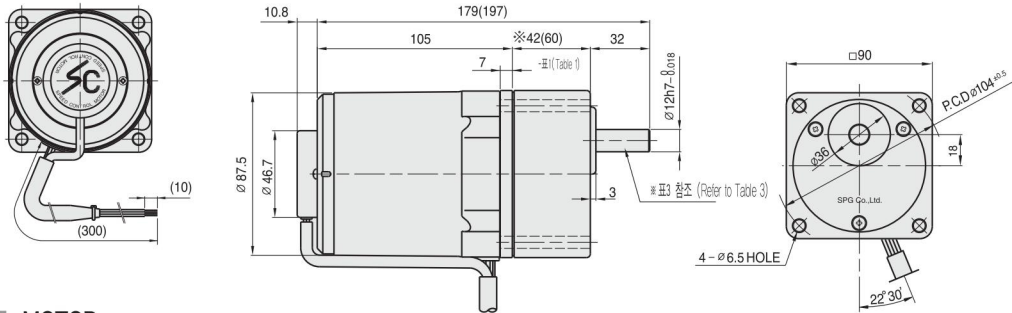

+ MOTOR

• MOTOR MODEL : S9R40□□□-S12, S9R40□□□-S24

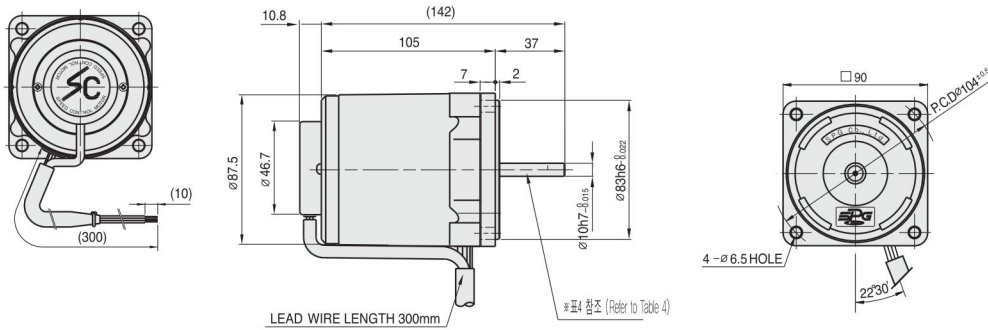

+ INTER-DECIMAL GEAR HEAD

• MODEL : S9GX10B(H,L)

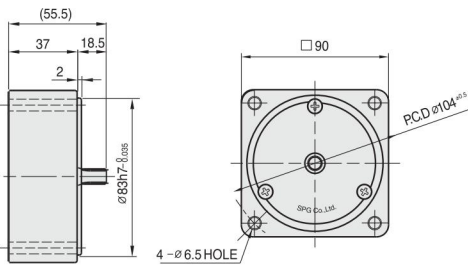

+ KEY SPEC

GEAR HEAD	MOTOR

+ MOTOR 출력축 사양 (SPEC for output shaft of motor) - (표4 Table4)

MODEL	출력축 구분 (TYPES OF OUTPUT SHAFT)
GEAR TYPE	
S9R40G□□-S12 S9R40G□□-S24	
STRAIGHT TYPE	
S9R40S□□-S12 S9R40S□□-S24	
D-CUT TYPE	
S9R40D□□-S12 S9R40D□□-S24	
KEY TYPE	
S9R40K□□-S12 S9R40K□□-S24	

+ ※42(60) - (표1 Table1)

GEAR RATIO	SIZE(mm)
S9□B3□ ~ S9□B18□	42
S9□B20□ ~ S9□B200□	60

+ WEIGHT - (표2 Table2)

PART	WEIGHT(kg)	
MOTOR	2.48	
DECIMAL GEAR HEAD	0.60	
GEAR HEAD	S9□B3□ ~S9□B18□	0.73
	S9□B20□ ~S9□B40□	1.03
	S9□B50□ ~S9□B200□	1.13

+ GEAR HEAD 출력축 사양 (SPEC for output shaft of gearhead) - (표3 Table3)

MODEL	출력축 구분 (TYPES OF OUTPUT SHAFT)
STRAIGHT TYPE	
S9SB3□ ~S9SB200□	
D-CUT TYPE	
S9DB3□ ~S9DB200□	
KEY TYPE	
S9KB3□ ~S9KB200□	