

3. 사양 및 치수

Specifications & Dimensions

■ 유닛 실크햇 중공형 (KSF - □ - □ - UH) Unit Silk Hat Hollow Shaft Type

구조도 Parts configuration

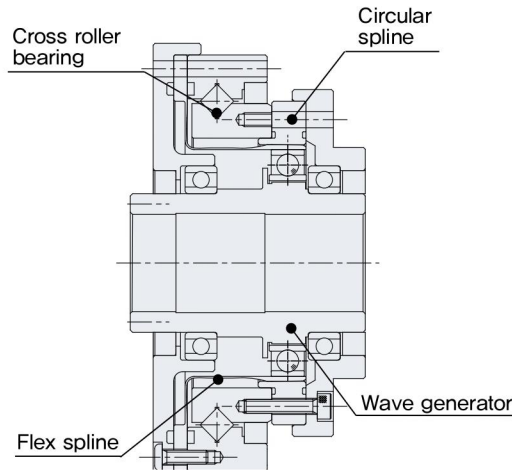

특징 Features

- 대구경 중공, 심플 디자인
Compact and simple design
- 우수한 위치결정정도와 회전정도
High positioning and rotational accuracies
- 고강성
High stiffness
- 고투크용량
High torque capacity
- 제로백래쉬
Non-backlash
- 우수한 위치결정정도와 회전정도
High positioning and rotational accuracies
- 입출력이 동축
Coaxial input and output

특성표 Specifications

형 번 No.	14			17				20				25				32					
감속비 Ratio	50	80	100	50	80	100	120	50	80	100	120	50	80	100	120	50	80	100	120		
입력 2,000r/min시 정격 토크 Rated torque at input 2,000r/min (Nm)	5.5	8	8	16	22	24	24	25	34	40	40	39	63	67	67	76	118	137	137		
기동, 정지시의 허용토크 Allowable torque when starting and stopping (Nm)	18	23	28	34	43	54	54	56	74	82	87	98	137	157	167	216	304	333	353		
평균부하토크의 허용최대치 Allowable maximum torque of average load torque (Nm)	6.9	11	11	26	27	39	39	34	47	49	49	55	87	108	108	108	167	216	216		
순간허용최대토크 Momentary maximum allowable torque (Nm)	35	47	54	70	87	110	86	98	127	147	147	186	255	284	304	382	568	647	686		
허용최고입력 회전속도 Allowable maximum input rotation speed (rpm)	오일윤활 Oil lubrication		14,000			10,000				10,000				7,500				7,000			
	그리스윤활 Grease lubrication		8,500			7,300				6,500				5,600				4,800			
허용평균입력 회전속도 Allowable average input rotation speed (rpm)	오일윤활 Oil lubrication		6,500			6,500				6,500				5,600				4,600			
	그리스윤활 Grease lubrication		3,500			3,500				3,500				3,500				3,500			
관성모멘트 Inertia moment (x10 ⁻⁴ kgm ²)	0.091			0.193				0.404				1.070				2.85					
중 량(kg) Weight	0.71			1.00				1.38				2.1				4.5					

Unit Silk Hat Hollow Shaft Type

형 번 No.	14			17				20				25				32			
감속비 Ratio	50	80	100	50	80	100	120	50	80	100	120	50	80	100	120	50	80	100	120
각도전달정도 Transmission Angular Accuracy (arcmin)	1.5	1.5	1.5	1.5	1.5	1.5	1.5	1	1	1	1	1	1	1	1	1	1	1	1
히스테리시스로스 Hysteresis Loss (arcmin)	2	1	1	2	1	1	1	2	1	1	1	2	1	1	1	2	1	1	1
기동토크 Starting Torque (cNm)	8.8	7.5	6.9	27	25	24	24	36	33	32	31	56	50	49	48	85	74	72	68
증속기동토크 Output Starting Torque (Nm)	5.3	7.2	8.2	16	24	29	34	22	31	38	45	34	48	59	69	51	70	86	97
라체팅토크 Ratcheting Torque (Nm)	88	110	84	150	200	160	120	220	350	260	240	450	680	500	470	980	1,400	1,000	980
좌굴토크 Buckling Torque (Nm)	140	140	140	270	270	270	270	440	440	440	440	890	890	890	890	1,750	1,750	1,750	1,750

강성 Rigidity

형 번 No.	14			17				20				25				32			
감속비 Ratio	50	80	100	50	80	100	120	50	80	100	120	50	80	100	120	50	80	100	120
T1 (kgfm)	0.2			0.4				0.7				1.4				3.0			
T2 (kgfm)	0.7			1.2				2.5				4.9				11			
K1 (kgfm/arcmin)	0.1	0.14	0.14	0.24	0.3	0.3	0.3	0.38	0.47	0.47	0.47	0.74	0.92	0.92	0.92	1.6	2	2	2
K2 (kgfm/arcmin)	0.14	0.18	0.18	0.32	0.4	0.4	0.4	0.52	0.75	0.75	0.75	1	1.5	1.5	1.5	2.3	3.2	3.2	3.2
K3 (kgfm/arcmin)	0.17	0.21	0.21	0.4	0.46	0.46	0.46	0.67	0.85	0.85	0.85	1.3	1.7	1.7	1.7	2.9	3.7	3.7	3.7
θ 1 (arcmin)	2	1.4	1.4	1.7	1.3	1.3	1.3	1.8	1.5	1.5	1.5	1.9	1.5	1.5	1.5	1.9	1.5	1.5	1.5
θ 2 (arcmin)	5.6	4.2	4.2	4.2	3.3	3.3	3.3	5.3	3.9	3.9	3.9	5.4	3.8	3.8	3.8	5.4	4.0	4.0	4.0

3. 사양 및 치수

Specifications & Dimensions

외형 치수 Dimensions

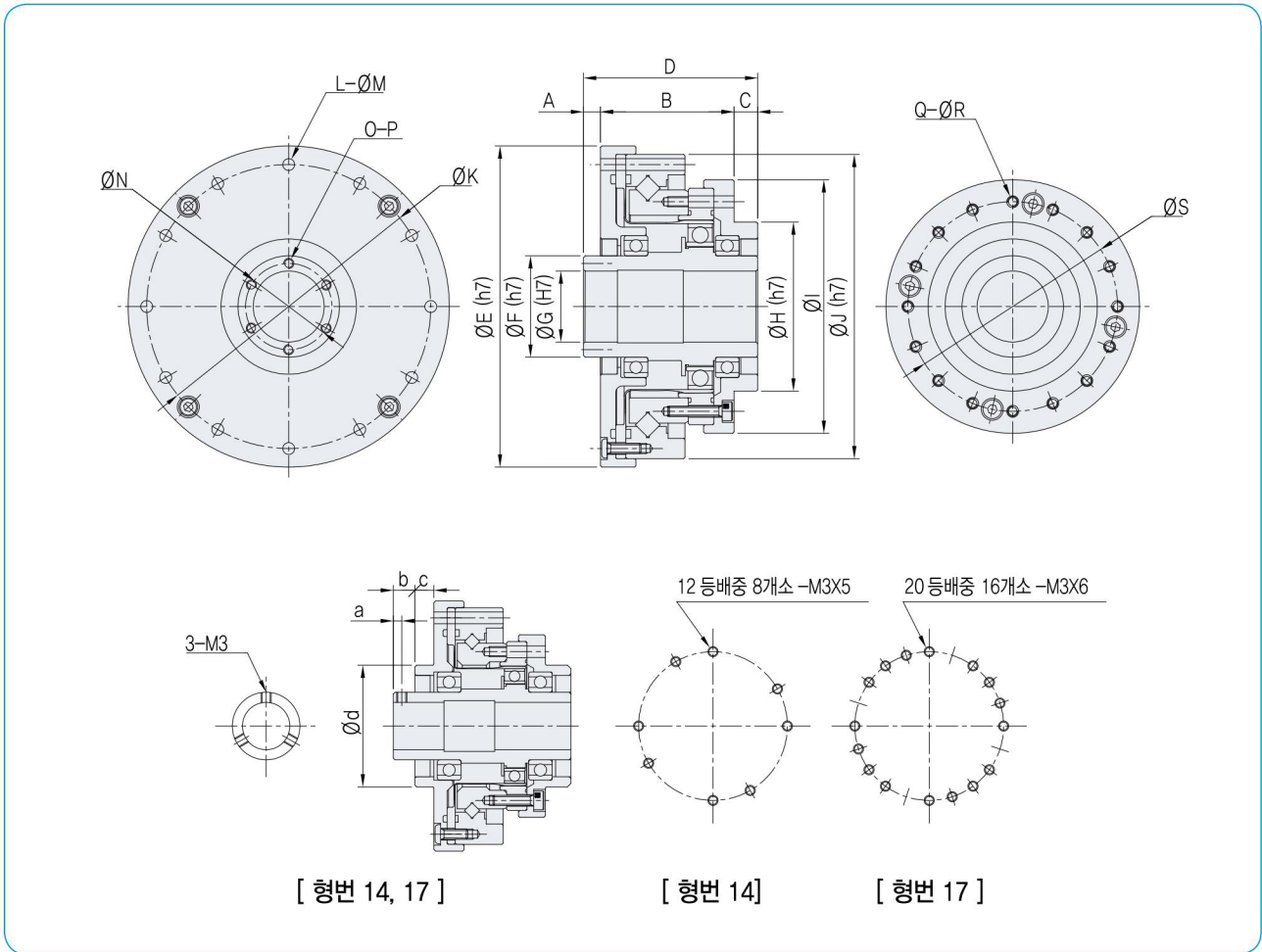

[mm]

형번 No.	A	B	C	D	ØE	ØF	ØG	ØH	ØI	ØJ	ØK	L
14	12	33	7.5	52.5	74	20	14	36	54	70	64	8
17	12	36	8.5	56.5	84	25	19	45	64	80	74	12
20	5	39.5	7	51.5	95	30	21	50	75	90	84	12
25	6	43.5	6	55.5	115	38	29	60	90	110	102	12
32	7	53.5	5	65.5	147	45	36	85	115	142	132	12

형번 No.	ØM	ØN	O	P	Q	ØR	ØS	a	b	c	Ød
14	3.5	-	-	-	8	3.5	44	2.5	6.5	5.5	36
17	3.5	-	-	-	20	3.5	54	2.5	6.5	5.5	45
20	3.5	25.5	6	M3	16	3.5	62	-	-	-	-
25	4.5	33.5	6	M3	16	4.5	77	-	-	-	-
32	5.5	40.5	6	M3	16	5.5	100	-	-	-	-

주) 1. 제품의 개선을 위해 예고 없이 치수 등을 변경 할 수 있습니다.
You can change dimensions without advance notice for product improvement.