



15W

ELECTROMAGNETIC BRAKE MOTOR
 80mm LEAD WIRE TYPE

SIZE mm sq.	Type	Poles	Output (W)	Voltage (V)	Frequency (Hz)	Duty	Rated Load				Starting Torque		Capacitor (uF)
							Current (A)	Speed (rpm)	Torque (kg-cm) (N-m)		(kg-cm)	(N-m)	
80	S8R15GA-E S8R15GA-E(TP) S8R15GA-ECE	4	15	1 ∅ 110	60	30min.	0.44	1550	1.00	0.100	1.50	0.150	6.0
	S8R15GB-E S8R15GB-E(TP) S8R15GB-ECE	4	15	1 ∅ 220	60	30min.	0.25	1600	1.00	0.100	1.50	0.150	1.5
	S8R15GC-E S8R15GC-E(TP) S8R15GC-ECE	4	15	1 ∅ 100	50	30min.	0.50	1200	1.30	0.130	1.25	0.125	6.0
	60				0.43		1500	1.10	0.110				
	S8R15GD-E S8R15GD-E(TP) S8R15GD-ECE	4	15	1 ∅ 200	50	30min.	0.28	1250	1.30	0.130	1.25	0.125	1.5
	60				0.24		1550	1.00	0.100				
	S8R15GE-E S8R15GE-ECE	4	15	1 ∅ 100	50	30min.	0.48	1300	1.30	0.130	1.25	0.125	6.0
	60				0.39		1600	1.10	0.110				
	60				0.45		1600	1.00	0.100				
	S8R15GX-E S8R15GX-ECE	4	15	1 ∅ 220	50	30min.	0.16	1200	1.30	0.130	1.25	0.125	1.0
	1 ∅ 240						0.17		1.40	0.140	1.45	0.145	

- 기종명 S8R15GE-E는 UL규격 인증 제품으로 THERMALLY PROTECTED TYPE입니다.(UL FILE NO. E172720) (S8R15GE-E is UL approved(UL FILE NO. E172720) thermally protected type.)
- 사용하는 전압 사양에 따라 CONDENSER 용량이 다르게 사용되므로 사용전압에 맞게 CONDENSER 용량을 바르게 사용하여 주십시오. 고장의 원인이 됩니다. 주문시 사용전압을 제시하여 주십시오. 제시가 없으면 115V용 CONDENSER로 포장 출하됩니다. (Appropriate capacitors shall be used according to the voltage for S8R15GE-E type since the size of the capacitor differs by different voltages. Malfunction may occur when not used properly. Capacitor for 115V will be delivered otherwise the required voltage is informed.)
- 기종명 맨 끝자리에 CE가 명기된 MODEL의 인증 관련 내용은 SPG 규격 인증품 현황을 참고하여 주십시오. S8R15GE-ECE는 115V용 사양으로만 출하됩니다. (CE marked at the end of model name indicates that it is thermally protected type which has received CE. S8R15GE-ECE is available only for 115V specification.)
- 기종명 맨 끝자리에 (TP)가 명기된 MODEL은 일반 MOTOR에 TP가 내장된 THERMALLY PROTECTED TYPE입니다. 또한 기종명 S8R15GE-E, S8R15GX-E는 TP가 내장된 THERMALLY PROTECTED TYPE입니다. (TP marked at the end of the model name indicates that it is standard motor with Thermal Protector mounted. S8R15GE-E, S8R15GX-E is thermally protected type with TP mounted.)
- 본 DATA는 전자 BRAKE MOTOR에서 전자 BRAKE를 제거하고 MOTOR 단독으로 측정된 DATA입니다. (Above data is measured with brake removed from electromagnetic brake motor.)
- 'L' Type 전용으로 기종명에 표시하지 않습니다. ('L' or 'H' type does not apply to motors under 40W.)

50Hz

GEAR RATIO		3	3.6	5	6	7.5	9	10	12.5	15	18	20	25	30	36	40	50	60	75	90	100	120	150	180	200
MODEL	rpm	500	416	300	250	200	166	150	120	100	83	75	60	50	41	37	30	25	20	16	15	12	10	8	7.5
	kg-cm	3.4	4.1	5.7	6.8	8.5	10.2	11.3	14.2	17.0	20.4	20.4	25.6	30.7	36.8	40.9	46.2	55.4	69.2	80	80	80	80	80	80
S8KA□B	N·m	0.333	0.402	0.559	0.666	0.833	1.000	1.107	1.392	1.666	1.999	1.999	2.509	3.009	3.606	4.008	4.530	5.433	6.786	7.840	7.840	7.840	7.840	7.840	7.840

60Hz

GEAR RATIO		3	3.6	5	6	7.5	9	10	12.5	15	18	20	25	30	36	40	50	60	75	90	100	120	150	180	200
MODEL	rpm	600	500	360	300	240	200	180	144	120	100	90	72	60	50	45	36	30	24	20	18	15	12	10	9
	kg-cm	2.9	3.5	4.9	5.8	7.3	8.7	9.7	12.2	14.6	17.5	17.5	21.9	26.3	31.5	35.0	39.6	47.5	59.4	71.3	79.2	80	80	80	80
S8KA□B	N·m	0.284	0.343	0.481	0.568	0.715	0.853	0.951	1.196	1.432	1.715	1.715	2.146	2.577	3.087	3.430	3.881	4.658	5.825	6.992	7.767	7.840	7.840	7.840	7.840

- GEAR HEAD 품명 중 □은 감속비를 표시합니다. (The code in □ of gearhead model is for gear ratio.)
- GEAR HEAD와 조합한 경우의 허용 TORQUE입니다. (It is the permissible torque of the assembled motor and gearhead.)
- 감속비 1/10의 중간 GEAR HEAD를 접속한 경우의 허용 TORQUE는 80kg-cm입니다. (The permissible torque of the motor and inter-decimal gearhead is 80 kg-cm.)
- 회전방향은 ■ 색이 MOTOR의 회전방향과 동일방향이고, 기타는 MOTOR 회전방향과 반대방향입니다. (■ color indicates that the output shaft of the geared motor rotates in the same direction as the output shaft of the motor. Others indicate rotation in the opposite direction.)
- 회전수는 MOTOR의 동기 회전수(50Hz : 1500rpm, 60Hz : 1800rpm)를 기준으로 하여 감속비로 나누어서 계산하였습니다. 실제의 회전수는 부하의 크기에 따라서 표시된 수치보다 2~20% 적습니다. (Rpm is based on synchronous speed (50Hz: 1500rpm, 60Hz: 1800rpm) divided by gear ratio. The actual rotation speed can be 2~20% less than displayed value depending on the load.)
- 'L' Type 전용으로 기종명에 표시하지 않습니다. ('L' or 'H' type does not apply to motors under 40W.)

DIMENSIONS

GEARED MOTOR

※ MOTOR MODEL : S8R15G□-E
 ※ HEAD MODEL : S8□A3□~S8□A200□

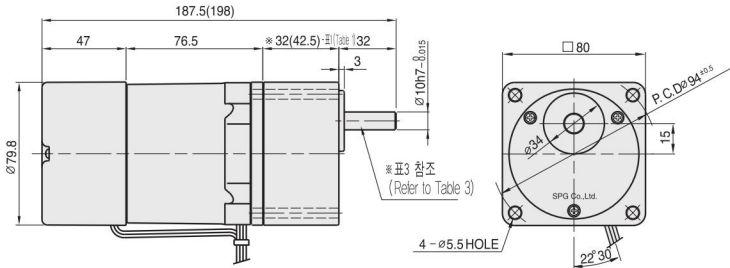

INTER-DECIMAL GEAR HEAD

※ MODEL : S8GX10B

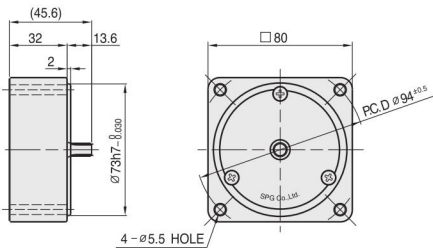

MOTOR

※ MOTOR MODEL : S8R15□□-E

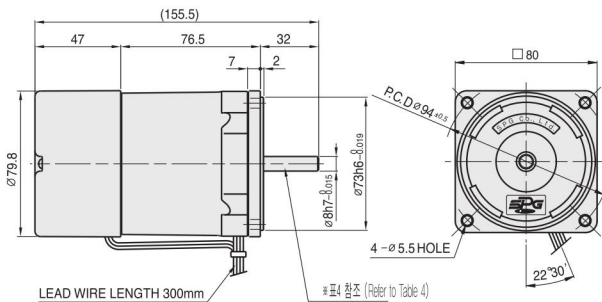

GEAR HEAD 출력축 사양 (SPEC for output shaft of gearhead) - (표3 (Table3))

MODEL	출력축 구분 (TYPES OF OUTPUT SHAFT)
STRAIGHT TYPE	
S8SA3□ ~S8SA200□	
D-CUT TYPE	
S8DA3□ ~S8DA200□	
KEY TYPE	
S8KA3□ ~S8KA200□	

※ 32(42.5) - (표1 (Table1))

GEAR RATIO	SIZE(mm)
S8□A3□ ~ S8□A18□	32
S8□A20□ ~ S8□A200□	42.5

WEIGHT - (표2 (Table2))

PART	WEIGHT(kg)	
MOTOR	1.86	
DECIMAL GEAR HEAD	0.43	
GEAR HEAD	S8□A3□ ~S8□A18□	0.43
	S8□A20□ ~S8□A40□	0.57
	S8□A50□ ~S8□A250□	0.61

KEY SPEC

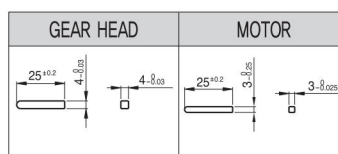

MOTOR 출력축 사양 (SPEC for output shaft of motor) - (표4 (Table4))

MODEL	출력축 구분 (TYPES OF OUTPUT SHAFT)
GEAR TYPE	
S8R15G□-E	
STRAIGHT TYPE	
S8R15S□-E	
D-CUT TYPE	
S8R15S□-E	
KEY TYPE	
S8R15K□-E	

SCHEMATIC DIAGRAMS

회전방향은 MOTOR의 SHAFT 끝쪽에서 볼 때의 회전방향입니다. (The direction of motor rotation is as viewed from the front shaft end of the motor.)

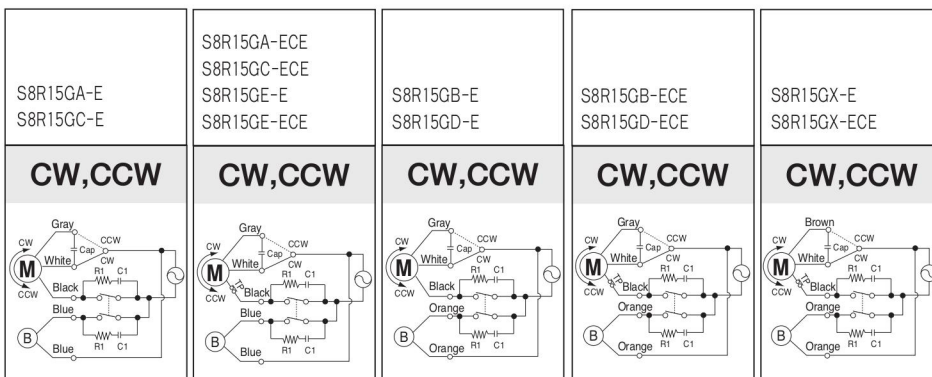

R1 = 10 ~ 200 Ω (Min. 1/4W)

C1 = 0.1 ~ 0.33 μF (AC125WV or AC250WV)